

**Information and Communication Technology Project for 1450
Government Schools, 5 Smart Schools and 70 newly upgraded
Government Schools**

**Tender Document for the supply and installation
of the Multimedia Educational Content, Teacher
training/ Refresher courses, Monitoring,
Interactive White Board, LCD Projector,
Integrated Computer Projector, Computer
Hardware, software, Manpower, other allied
accessories (i.e. webcam, multifunctional
Printers, UPS, etc.), site preparation (i.e. vinyl
flooring, furniture and fixtures, electrical fittings,
LAN, etc.) and Maintenance thereof.**

**On
Build Own Operate Transfer (BOOT) basis**



**Directorate of Higher Education
Himachal Pradesh
Lalpani, Shimla-171001**

IMPORTANT INFORMATION

Non-Refundable Tender Cost	Rs. 10,000/- (Rupees Ten Thousand only) through demand draft from a Nationalized Bank, drawn in favor of "Director of Higher Education, Himachal Pradesh", payable at Shimla The tender document is nontransferable.
Sale of Tender document	All working days during office hours w.e.f 28-02-2014 10:00 AM to 31-03-2014 upto 5:00 PM
EMD:	The Bidders has to submit Earnest Money Deposit (EMD) in favour of Director of Higher Education: Rs.30 Lac only in form of Demand Draft from a Nationalized Bank drawn in favor of Director of Higher Education, Himachal Pradesh payable at Shimla
Date, Time and Venue of Pre Bid meeting	18-03-2014 at 2:00 PM, RMSA Conference Hall, Directorate of Higher Education, Lalpani, Shimla-171001
Last date for submission of Bids	02-04-2014 upto 1:00 PM
Opening of Pre-Qualification Bids	02-04-2014 at 2:00 PM

Table of Contents

Sr.	Contents	Page
1	Preface and Project Profile	5
2	Preface	5
3	Project Profile	6
4	Section II: Schedule of Requirements	8
5	Scope of Work for ICT in 1450 Govt. Schools, 5 Smart Schools and 70 Govt. School	8
6	Multimedia Based Educational Content	9
7	Features of CAL	11
8	Instructions	11
9	Physical Infrastructure Requirement	12
10	Power Backup Arrangement	13
11	IT Infrastructure Requirement	13
12	Training of Teachers	16
13	Monitoring & Refreshers	18
14	Manpower requirement	19
15	Services	20
16	Duration of Contract	21
17	Location of Schools	22
18	Table A- Specifications	22
19	Section-III : Instructions to Bidders	38
20	Definitions	38
21	Eligibility Criteria	40
22	General Conditions	40
23	Implementation Schedule	41
24	Bid Document	41
25	Sub-letting of the Contract	45
26	Pre-bid Conference	45
27	Amendment of Bid Document	45
28	Cost of Bid Document	46
29	EMD	46
30	Bid Validity	47
31	Submission of proposals	47
32	Language	49
33	Late Bids	49
34	Penalty & termination Clauses	49
35	Acceptance and withdrawal	52
36	Bid Forms	53

37	Local conditions	53
38	Opening of Proposals	53
39	Evaluation & Selection Criteria	54
40	Source Code & IPR	59
41	Language of bid & Correspondence	59
42	Bid Currencies	59
43	Deciding the Award of Contract	59
44	Confidentiality	60
45	Publicity	61
46	Insurance	61
47	Arbitration	61
48	Legal jurisdiction	61
49	Payment Structure	62
50	Section IV: Special Condition of Contract	63
51	Performance Bank Guarantee for Operations	63
52	Site preparation and Survey	63
53	Force Majeure	63
54	Representation and warranties by bidder	64
55	Annexures	65

Section I - Preface and Project Profile

1. Preface

- a. The Department of Higher Education, Government of Himachal Pradesh, has taken a number of initiatives in the past few years to provide IT infrastructure and IT education in Government Senior Secondary Schools of the state.
- b. At present, IT education is being imparted in 1232 Government Senior Secondary Schools of the state on self financing basis under an agreement valid upto 2013-14.
- c. Similarly, Department of Higher Education Himachal Pradesh has provided basic IT infrastructure within the College premises to support and cater to the basic IT needs of the students. IT Labs are available in the colleges to meet the curriculum requirement of regular courses like Bachelors of Science, Computer Applications, Arts, and Commerce etc.
- d. It has however been felt that a more comprehensive and integrated approach to Computer Aided Learning & Teaching is required to prepare the students of schools to take maximum advantage of the knowledge economy.
- e. **Information and Communication Technology (ICT)** in Government Senior Secondary Schools of Himachal Pradesh is a window of opportunity to the learners in the Government Senior Secondary Schools in Himachal Pradesh to bridge the digital divide. The scheme is a comprehensive and well thought-out initiative to open new vistas of Computer Aided Learning (CAL) and to provide a level-playing field to government school students.
- f. The Department of Higher Education, Himachal Pradesh has already established integrated Information and Communication Technology (ICT) Labs and smart classrooms in 628 Government Senior Secondary Schools of the state
- g. The Department of Higher Education proposes to closely integrate the critical components into a framework, incorporating the learning and best practices from the similar initiatives at the global level and practical needs of the evolving knowledge society.
- h. The Department of Higher Education, Himachal Pradesh intends to implement the ICT project on Build Own Operate Transfer (BOOT) basis for all the liabilities covered under the scope of work mentioned in this tender document for 1450 Government Schools (615 Govt. Sr. Sec. Schools + 835 Govt. High School), 5 Smart Schools (Govt. Sr. Sec. Schools) and 70 newly upgraded Government Schools (55 Govt. Sr. Sec. Schools + 15 Govt. High School) across the State. The list of 1450 Government Schools (615 Govt. Sr. Sec. Schools + 835 Govt. High School), 5 Smart Schools (Govt. Sr. Sec. Schools) and 70 newly upgraded Government Schools (55 Govt. Sr. Sec. Schools + 15 Govt. High School) is annexed as **“Annexure-M”**
- i. The Department of Higher Education invites sealed pre-qualification, Technical and commercial proposals from eligible Bidders for selection as “BOOT Operator”, to implement ICT Project in 1450 Government Schools (615 Govt. Sr. Sec. Schools + 835 Govt. High School), 5 Smart Schools (Govt. Sr. Sec. Schools) and 70 newly upgraded Government Schools (55 Govt. Sr. Sec. Schools + 15 Govt. High School) in HP. The bidder shall be selected as

- per the procedures described in this tender document.
- j. Bidders may note that Bids are to be submitted as per the instructions laid out in **Section III** of the tender document. The selection of BOOT operator would be a three step process:
- 1) Prequalification Bid
 - 2) Technical Bid
 - 3) Commercial Bid
- l. The last date for submission of the bid is **02-04-2014** upto **1:00 PM** to the following address which is to be used for all communication in regard to this bid process.

Director of Higher Education
Below Bus Stand, Lalpani, Shimla-171001
Tel No:- (91)0177-2656621, 2653922
Fax No: - (91) 0177-2811247, 2812882
E-mail: dir.edu@rediffmail.com
Website: www.educationhp.org

2. Project Profile

The Department of Higher Education intends to implement Information and Communication Technology (ICT), as an initiative to use ICT tools to enhance the skill levels for inculcating knowledge and skills appropriate for the twenty first century in young students in 1450 Government Schools (615 Govt. Sr. Sec. Schools + 835 Govt. High School), 5 Smart Schools (Govt. Sr. Sec. Schools) and 70 newly upgraded Government Schools (55 Govt. Sr. Sec. Schools + 15 Govt. High School) of Himachal Pradesh.

a. The salient features of the Project implementation approach are as follows:

- i. Information and Communication Technology (ICT) Framework:** The Project is to be implemented on a Build Own Operate Transfer (BOOT) basis. The successful bidders responsibilities include supply, installation and maintenance of Multimedia Educational Content, teacher training, manpower, refreshers, monitoring, LCD Projector, Interactive White Board, Computer Hardware, software and other allied accessories (i.e. Webcam, Multi-Functional Printers, UPS, etc.), site preparation (i.e. vinyl flooring, furniture and fixtures, Electrical fittings, Power Back Up Facilities, LAN, etc.), etc. The successful bidder will also maintain and upkeep the ICT Lab, and two Smart Class Rooms throughout the contract period. The Department will provide one room for ICT Lab (existing ICT Lab in case of 5 Smart Schools) and two rooms for smart class rooms in all the 1450 Government Schools (615 Govt. Sr. Sec. Schools + 835 Govt. High School), 5 Smart Schools (Govt. Sr. Sec. Schools) and 70 newly upgraded Government

Schools (55 Govt. Sr. Sec. Schools + 15 Govt. High School) covered under this project to the successful bidder.

- ii.** Supply & installation of Multimedia Educational Content for Computer Aided Teaching & Computer Aided Learning will be as mentioned below based on Himachal Pradesh School Education Board syllabus.

Sr. No.	Subject	Class	Language of the Content
1	Physics, Chemistry, Biology, English, Mathematics	11 th & 12 th	English
2	Commerce, Geography, Economics, History, Political Science.	11 th & 12 th	Hindi (Terminology in Hindi & English)
3	Social Science, Hindi, Science, Mathematics	9 th & 10 th	Hindi (Terminology in Hindi & English)
4	English	9 th & 10 th	English

- iii.** Provide training on usage of supplied Multimedia Educational Content, operations of all the hardware installed and browsing of internet in the schools to all the subject teachers in the designated training centre provided by the department. Subsequent refreshers course
- iv.** Monitoring through online MIS and subsequent reports.

- b. Program Monitoring Body:** The Department of Higher Education will also monitor the Project itself with the help of Dy. Directors of Higher Education and Nodal Officers (IT) located at District Headquarters.

Section II: Schedule of Requirements

Bidder is required to undertake the Scope of Work for schools as mentioned below:

1. Scope of work for ICT in 1450 Government Schools, 5 Smart Schools and 70 newly upgraded Government Schools

- a. Supply, installation and maintenance of Multimedia Educational Content for Computer Aided Teaching & Computer Aided Learning as mentioned below strictly based on Himachal Pradesh School Education Board syllabus. The Bidder will have to develop multimedia educational content for 10+2 class as per the syllabus prescribed by NCERT.

Sr. No.	Subject	Class	Language of the Content
1.	Physics, Chemistry, Biology, English, Mathematics	11 th & 12 th	English
2.	Commerce, Geography, Economics, History, Pol.Sc.	11 th & 12 th	Hindi (Terminology in Hindi & English)
3.	Social Science, Hindi, Science, Mathematics	9 th & 10 th	Hindi (Terminology in Hindi & English)
4.	English	9 th & 10 th	English

- b. Maintenance of Multimedia Educational Content and the equipments/hardware installed in the smart class rooms/ICT Lab throughout the contract period.
- c. Provide training on usage of supplied Multimedia Educational Content, operations of all the hardware installed and browsing of internet in the schools to all the subject teachers in the designated training centres provided by the department. Subsequent refreshers courses as and when required.
- d. Monitoring & fault logging through online MIS and subsequent reports.
- e. Two rooms will be provided to the bidder for converting them into Smart Class Rooms.
- f. The bidder has to supply and install an Interactive white board in both the Smart Class rooms alongwith either **Option A or Option B or Option C**

Option-A

- Laptop with external Mouse, 650 VA Line Interactive UPS for providing power backup to LCD Projector in each of 1450 Government Schools, 5

smart schools and 70 newly upgraded Government Schools. The bidder has to provide a wall fixed wooden cabinet furniture for keeping the Laptop, Mouse and the UPS in both the Smart class rooms. The internal structure of wooden cabinet might have to be changed slightly depending upon the size of UPS, Laptop etc.

- (Refer Table A for the Specification).

Or

Option-B

- Bidder can supply & install Integrated Computer Projector with 1 KVA Line Interactive UPS in each of 1450 Government Schools, 5 smart schools and 70 newly upgraded Government Schools. The bidder has to provide a wall fixed wooden cabinet furniture for keeping Integrated Computer Project Keyboard, Mouse and UPS (Refer Table A for the specifications). The internal structure of wooden cabinet might have to be changed slightly depending upon the size of Integrated Computer Projector.

or

Option-C

- Bidder can supply & install Integrated Classroom Equipment/Multi feature Device with Computing & Image Projection with in-built Interactivity alongwith 1 KVA Line Interactive UPS in each of 1450 Government Schools, 5 smart schools and 70 newly upgraded Government Schools. The bidder has to provide a wall fixed wooden cabinet furniture for keeping Integrated Computer Project Keyboard, Mouse and UPS (Refer Table A for the specifications). The internal structure of wooden cabinet might have to be changed slightly depending upon the size of Integrated Computer Projector.
- g. The bidder has to provide the power point fittings in both the smart class rooms to run the equipments being installed in the Smart Class rooms.
- h. The bidder will ensure that the Multimedia Educational Content run properly on all the hardware installed in ICT lab and smart class rooms.
- i. All the deliverables should bear a sticky label having contents “ICT@School Project HP Phase-II”.
- j. The bidder will provide batteries for remote control of Projectors etc.: As per requirements

2. Multimedia Based Educational Content

The bidder shall develop the multimedia educational content having following features. The related activities include:-

- Understanding the requirement for developing and installation of customized Computer aided teaching and Computer Aided Learning product.

- **Conceptualizing the multimedia content based on story lines, minimum 2D animation, interactive games, live coverage, real life example, music and riddles having good voice over etc.**
- Planning in detail, the content development during Pre-production, Production and Post- production stages.
- Development of content with full multimedia quality control. The duration of the content developed should be at least 1/3 of total duration of the periods allotted for topic/chapter in the syllabus. The duration of a period is 30 minutes.
- The multimedia educational content should be categorized class wise and subject wise folders on the DVD/DVDs.
- The bidder will also provide multimedia educational content usage utility in order to assess the exact usage of content in each smart class room. The utility should generate subject wise, class wise and teacher wise usage report of each hard spot taught in the smart class room.
Supply of the multimedia Educational Content and the Installation Manual, Manual of academic content, Administration Manual and User Reference in English) on DVD media class wise and subject wise as follows:

- a) One set in each of the 1450 Government Schools, 5 smart schools and 70 newly upgraded Government Schools.
- b) One set in the office of Dy. DHE of each district
- c) One set in the Directorate of Hr. Education Shimla

These sets shall be checked and verified at Directorate/Dy. DHE level before actual delivery and installation at school level.

Important Note

- The bidder has to consult the syllabus and books prescribed by the Himachal Pradesh Board of School Education Dharmshala/NCERT, before developing Multi-media Educational Content. He will also make his own arrangements for the procurement of syllabus and books. Moreover, in case of any change in syllabus at any point of time during contract period, the bidder has to supply Multimedia Educational Content on the new topics incorporated/changed on additional payment basis. The bidder will quote for per 10 minutes price for multimedia educational content in the commercial bid. The price quoted will be applicable throughout the contract period

3. Required features of the Software keeping in mind CAL for student oriented, CAT for teacher oriented, aptitude and ability of the children:-

- **User Interface:** The proposed system components should be simple comprehensive, learner centric and easy to use.
- **GUI:** The proposed solution should be based on graphical interpretation and windows architecture.
- **Learning Objective:** The Multimedia content should meet out all the academic objectives in respect of all the multimedia educational content.
- **Interactive:** Multimedia contents should provide many interactions during the use of Multimedia Educational Content. There should have a facility whereby a teacher/student can stop at any point and restart after a pause from the same point in the topic. All modules should have pause, play, fast forward, index, assessment and rewind facilities.
- **Learning approaches:** 2-3 different learning approaches should be used during the preparation of the contents.
- **Accuracy:** The contents should be clearly represented, structured and accurate.
- **Accessibility:** All contents should be accessible with good response time.
- **Other features:** Quality of contents, innovation, instructional language of content, flow of logic, clarity and relevance of voice over, methodology, assessment, and examples etc.
- **Voice Over:** The voice of Male and female experts be used during recording.

4. Instructions

- a. Concepts should be explained through good and effective graphics, and animations based on imaginative analogies.
- b. The bidder should ensure proper installation of the Multimedia

Educational Content on the equipments/hardware installed in the ICT lab and two smart class rooms in each of 1450 Government Schools + 5 smart schools + 70 newly upgraded Government Schools and their proper functioning on all the equipments. The Principal of the school concerned will certify the successful installation.

The installation of Multimedia Educational Content shall be done at the risk and cost of the bidder.

- c. If any technical/operational defects are found in the Multimedia

Educational Content at any point of time (during the period of contract), the same will have to be rectified/replaced free of cost by the bidder. The bidder is also bound to make the necessary modification in the Multimedia educational content as per the feedback received from the teachers throughout the contract period.

- d. The content developed will be the property of Government of Himachal Pradesh and it can be used by the department in other schools in the state also without seeking consent of the bidder and without paying any extra cost for unlimited period of time.
- e) All equipments once installed in ICT Lab and smart class rooms will not be taken away by the bidder in any case. After the expiry of the contract period, the entire infrastructure supplied and installed will be transferred to the department/Government of Himachal Pradesh at zero transfer value.

5. Physical Infrastructure Requirement

The Bidder is required to supply and install the Computer Hardware, software and other allied accessories, (i.e. webcam, multi-functional printers, UPS, etc.) site preparation (i.e. vinyl flooring, furniture and fixtures, electrical fittings, LAN, etc.) in the 1450 Government Schools, 5 smart schools and 70 newly upgraded Government Schools. Bidder will Maintain and upkeep the ICT Lab during the **contract period**. The entire infrastructure to be provided as per requirement as a part of the project must be new and branded as per the specifications laid out in the tender document.

a) Physical Infrastructure:

i. Site Preparation:

The bidder will be provided with **1 room (grilled)**. The bidder has to undertake all other necessary activities required for establishing the ICT Lab in 1450 Government Schools and 70 newly upgraded Government Schools. Bidder is required to apply Plastic vinyl flooring as per the specification mentioned in the **Table-A** in ICT Lab. The bidder will apply vinyl flooring in an area of 400 sq. feet $\pm 10\%$ maximum or actual whichever is less. In case of ICT Lab to be established in 5 smart schools, a room already having vinyl flooring will be provided to the bidder.

ii. Electrical wiring and equipments:

- The bidder has to undertake electrical wiring (of ISI marked & branded) for all electrical and IT equipments like PCs, Server, Multifunctional Printer, UPS etc. in 1450 Government Schools and 70 newly upgraded Government Schools.
- Electrical wiring would also include proper earthing arrangements.

- In case of 5 smart schools, the bidder will have to undertake electrical wiring for 8 desktop computers and 32 nodes.

The bidder is required to provide internal electric wiring and power point fittings as per the design of fixed assembly annexed as Annexure “k”.

Wiring (All equipments/ appliances /fittings should be ISI/ISO certified)

iii. Furniture & Fixtures:

The bidder has to provide furniture for ICT Lab like chairs etc. Furniture would include

- In One Class Room: (ICT Lab) Fixed table assembly for 2 desktop computers and 8 nodes as per the design annexed as Annexure- “K” and 30 PVC/Plastic moulded chairs without arm rest for the students.
- Beside this, the bidder will have to provide fixed table assembly in continuity to the existing fixed table assembly already installed in ICT labs of 5 smart schools having a capacity of placing 8 desktop computers and 32 nodes in shared computing mode. The bidder will also provide 80 PVC/Plastic moulded chairs without arm in each of the 5 Smart Schools.
- Refer **Table A** for the furniture specifications.

b) Power back up Arrangements

i. UPS:

- The bidder has to provide a 1 KVA online UPS in ICT lab in 1450 Government Schools, 5 smart schools and 70 newly upgraded Government Schools. The bidder will ensure that the UPS provides full rated backup throughout the contract period. Bidder would be responsible for maintenance/replacement of batteries whenever required during the contract period at his own cost to ensure requisite backup.
- The bidder has to exercise either option-A or option-B or option-C mentioned under clause scope of work (i) f for providing UPS in Smart Classrooms.
- In case of 5 Smart Schools, the bidder will have to provide 6 KVA online UPS for supporting 8 desktop computers and 32 node connections in each school.
- Refer Table-A for specifications.

c) IT Infrastructure Requirements:

i. Computers:

- The Bidder is required to provide 2 desktop computers & shared computing solution with 4 nodes connection (two sets) to connect with the two main computers in ICT Lab in each of 1450 Government Schools and 70 newly upgraded Government Schools.

- The bidder shall provide 7 laptops for Directorate of Hr. Education and 1 Laptop for each of 12 Dy. Director of Hr. Education offices at District Headquarter for project monitoring purpose. Bidder may note that the scope of work includes all services (AMC /insurance /repair /maintenance /spares /instant replacement in case of theft etc.).
- In case of 5 Smart Schools, the bidder will have to provide 8 desktop computers & shared computing solution with 32 node connections (8 sets) to connect with 8 main computers in each school.
- Refer Table-A for specifications.

ii. Printer/ Scanner/Copier/FAX:

- The bidder has to provide 1 Multifunctional Laser Printer with facility of Print, Scan, Copy & Fax (incoming & outgoing) in ICT Lab in each of the selected 1450 Government Schools and 70 newly upgraded Government Schools.
- One Multifunctional Laserjet Printer at Directorate of Higher Education and 1 Multifunctional Laserjet Printer at each 12 Dy Director of Hr. Education offices at Distt. Headquarter for monitoring. The Printer installed in ICT Lab should be on the network.
- In case of 5 Smart Schools, the bidder will have to provide 2 Multifunctional Laser Printers with facility of Print, Scan, copy & Fax (incoming & outgoing) in each school. The printers so installed should be on network.
- Refer Table-A for specifications.

iii. Web Camera:

- Bidder has to provide one web camera in ICT Lab in each of 1450 Government Schools and 70 newly upgraded Government Schools. In case of 5 Smart Schools, the bidder will have to provide and install 2 web cameras in each school.
- The bidder has to provide 2 web cameras for Directorate of Higher Education and one each for 12 Dy. Director of Higher Education Offices.
- Refer Table-A for specifications.

iv. LAN Equipment:

- The bidder has to provide one 8 port switch in each of the ICT labs of 1450 Government Schools and 70 newly upgraded Government Schools.
- In case of 5 Smart Schools, the bidder will have to provide and install one 16 port switch in each school.

- Refer Table-A for specifications.

v. Interactive White Board:

- The bidder has to provide and install an Interactive White Board in each of the Smart Class room in all the 1450 Government Schools, 5 smart schools and 70 newly upgraded Government Schools at a suitable height. Refer Table-A for the specifications.

vi. LCD Projector/Integrated Computer Projector:

- The Bidder has to provide a LCD Projector/Integrated Computer Projector/ Integrated Classroom Equipment/Multi feature Device with Computing & Image Projection with in-built Interactivity in each of the smart class rooms in all the 1450 Government Schools, 5 smart schools and 70 newly upgraded Government Schools. Also, the bidder has to provide one projector along with projector screen at Directorate of Higher education and in each of the 12 Dy. Directors of Hr. Education offices at Distt Headquarters.
- Refer Table-A for the specifications.

vii. Internet:

- The department will provide Unlimited Broadband Internet connectivity in 1450 Government Schools, 5 smart schools and 70 newly upgraded Government Schools.
- The bidder will ensure that the internet access should be available in ICT lab and in both the smart class rooms. The bidder will provide the necessary networking/connectivity from ICT lab to Smart Class rooms as per requirement. During the contract period bidder will ensure the proper connectivity of the internet at school level.

vii. Registers for Fault logging cum Penalty Register (having minimum 200 pages) and Stock Register (having minimum 200 Pages) in each of 1450 Government Schools, 5 smart schools and 70 newly upgraded Government Schools.

viii. Consumables:

Bidder will provide the following consumables in each of 1450 Government Schools, 5 smart schools and 70 newly upgraded Government Schools:

- One ream of white paper A4 size (min 75 GSM) per month per ICT lab.
- **Printer Cartridge:**
One new printer cartridge per quarter during the contract period.

- **DVDs:** Blank 15 RW DVD" s per year per ICT Lab

ix. Software's:

The bidder has to provide following software & users licenses for 54 and 108 Smart Class rooms, required for the functioning of ICT lab and smart class rooms:-

Windows Multipoint Server Premium 2011 SNGL OLP NL Academic OS for Servers Clients for Multipoint Server Partner in Learning Program (PIL) includes Windows with 5 Yrs updates & Upgrades, MS Office Professional 2010, Visual Studio 2010 Professional, Encarta AE latest Version (downloadable). The indicative list of software's is mentioned in the **Table-A Technical Specification.**

The Department will provide the above mentioned software and licenses for remaining users required for the functioning of ICT lab and smart class rooms. The software will be provided to the bidder in the form of media at a central location (Directorate of Higher Education, Shimla). The bidder will have to install all the software/upgrades/patches etc. in the ICT lab and Smart class rooms as and when required during the contract period. The indicative list of software's is mentioned in the **Table-A Technical Specification.**

Bidder will provide the Software and user licenses for Filtering/Blocking of un-wanted contents and Creativity in Learning Program in each of 1450 Government Schools, 5 smart schools and 70 newly upgraded Government Schools. The indicative list of software's is mentioned in the **Table-A Technical Specification.**

v. Electricity:

The Electricity will be provided by the concerned school during the contract period.

6. Training of Teachers and other Staff

The bidder will train at least 7500 teachers on usage and integration of multimedia educational content in the lesson plans. Due attention should be given to the following aspects:-

- Proper proposal including curriculum for the training will be designed and submitted by the company at the time of signing of agreement and shall be got approved by the DIRECTOR OF HIGHER EDUCATION, Himachal Pradesh.
- The training for 3 working days for about 7500 teachers for usages of

Multimedia educational content and handling of hardware installed in the Smart Classroom and ICT Lab during implementation time.

- There should be special emphasis on practical training (operating computers for the use of multimedia educational content).
- The venue and infrastructure for the training will be provided by the DEPARTMENT OF HIGHER EDUCATION. The Department shall provide 20 to 25 venues or more as training centers located all over the State (List of training centres with available hardware has been annexed as "H"). Beside this any additional equipment required to run the multimedia educational content has to be provided by the successful bidder. The bidder will be allowed to take away the additional supplied hardware/equipment from the training centres after the completion of the training.
- During the training programme there will be about 40 teachers in a batch and the training schedule should be of 6 hrs per day i.e. 10:00 AM to 5:00 PM.
- The service provider will deploy 2 subject wise Master Trainer per training centers for a batch. The recruitment, retrenchment, reallocation and salary of the training staff are exclusive prerogative and responsibility of the service provider.
- After the completion of the training the concerned Principal of the training centre will issue the certificate to the bidder whether the training is satisfactory (by taking the feedback from the trainees) and conducted as per the schedule.
- The expenditure involved in r/o of TA/DA of teachers training, will be paid to the teachers from their concerned schools.
- Thereafter, the concerned school IT/ICT Teacher will provide training to the teachers at school level regarding usage and integration of multimedia educational content in the lesson plans. The training should comprise of usages of Multimedia content and browsing of internet for academic content. The Basic computer training shall include basics about Computers, Configuring and installing devices, Internet usage, email, Operating Systems and MS Office. There should be special emphasis on practical training on the operation of all the hardware/equipment's/software's installed in ICT lab, Smart Class rooms and the use of multimedia educational content, Interactive white board etc. IT/ICT teacher will also provide training to the ministerial staff and concerned school Principal regarding MS office, Internet, software's operational in department and the feeding /operation of MIS software to ensure the timely and correct data feeding.

Qualification of Trainers:

The Master Trainer must be Post Graduate from a recognized University in the concerned subject and having full knowledge of multimedia educational content and its usage. Bidder may also provide assistant trainer, if required.

7. Monitoring & Refreshers:

The bidder will have to provide online MIS solution for monitoring and usage of all components under ICT project such as multimedia educational content, hardware, software, penalties etc. The MIS will be made operational **within 3 months** of date of signing of agreement between the department and successful bidder. The MIS may be modified later on as per the recommendations of the Department. The reports generated from MIS will be used to analyze the outcome of the project.

The MIS should comprise of the following:

- a. Subject teacher wise usage of multimedia educational content in the schools?
- b. Difficulties/problems in using the multimedia educational contents & internet access?
- c. The benefit or improvement in teaching by multimedia educational content and internet access.
- d. The benefit to the student in learning through multimedia.
- e. Any other important aspect as per proposal of bidder.
- f. Status of hardware installation, performance and maintenance by the bidder.
- g. The school wise number of teachers Trained and refresher programmes conducted.
- h. Category wise and class wise beneficiaries.
- i. Details of teacher training and refreshers conducted
- j. Supply of consumables and stationary

The MIS should generate reports regarding the outcome reflecting short comings, achievement as well as suggestions for improvement. The concerned school Principal will keep the copies of various reports for office records.

Refreshers:

The service provider will also provide 2 days refresher training of teachers. The first refresher will be conducted after the SIX months from the date of completion of implementation schedule and thereafter one refresher per year will have to be conducted during the contract period. The block level sites will be provided to the bidder for conducting refreshers. The refreshers must be

conducted as mentioned above immediately within one month after the time mentioned above.

Operational Scope of the Contract:

The Director of Higher Education may appoint a Committee at Directorate level and they will have full powers to visit the schools and Training Centers to check and verify the proper implementation of the project. The decision of the committee will be final with respect to the adherence to the scope of work and its applicability as per the schedule by the bidder at the target schools and accordingly the penalty will be imposed on the bidder.

The Bidder will maintain and upkeep all the hardware/software/site preparation and components covered under the scope of work in all the allotted schools during the **contract period**. The entire infrastructure to be provided as per requirement as a part of the project must be new and branded as per the specifications laid out in the tender document.

1. Manpower Requirements:

a) State Project Officer (SPO):

The bidder will have to provide one State Project Officer to coordinate, implement and to provide regular feedback and reporting regarding the project. The bidder will provide the appointment letter alongwith the eligibility documents to the Directorate of Higher Education. The SPO should be bonafide himachali only.

Educational Qualifications for SPO:

- B.Tech/MCA/MSc (Comp Sc./IT) from a recognized University.
- Minimum 3 years project management experience in handling such large school implementation project preferably in Himachal Pradesh.

Roles and responsibilities of SPO:

- To ensure smooth implementation of the project.
- To coordinate and cooperate with the o/o the Directorate of Higher Education.
- Monitoring the performance of supporting staff.
- Infrastructure maintenance and upkeepment of Hardware, software and Multimedia Educational Content.
- To get the desired data, reports on time.
- To schedule and conduct refresher programme of teachers in consultation with the departmental authorities.
- To provide training to the ministerial staff and concerned school

Principal regarding MS office, Internet, software's operational in department and the feeding /operation of MIS software to ensure the timely and correct data feeding.

The Govt. shall not have any liability including litigation arising due to recruitment, retrenchment, reallocation, salary disbursement or any other service conditions of State Project Officer /any other staff appointed by the bidder. In case of any dispute/litigation arising as a result of the service conditions, the said dispute/litigation will be the exclusive dispute/litigation between the State Project Officer/ any other staff appointed by the bidder and the bidder. The H.P. Govt. / Department of Higher Education/Deputy Director of Higher Education of concerned district/ Principal of the concerned school or any other govt. agency will have no responsibility or liability in all such matters.

8. Services:

- i. The bidder has to manage and maintain in working condition the complete ICT lab and Smart Class rooms covering hardware, software, multimedia Educational Content and necessary infrastructure like UPS, furniture and fixtures etc. for the entire contract period.
- ii. The bidder will have to establish a help desk at Shimla in its own office and which shall remain open from 9 AM to 5 PM. The bidder/OEM will also have to appoint district wise requisite number of manpower/resident engineers at district level helpdesk for quick rectification of the hardware/software. At the time of signing of agreement, the bidder will have to provide the information of district wise manpower deployed alongwith the telephone numbers.
- iii. Installation of software's /upgrades/patches from time to time.
- iv. The Principal of the concerned school will be responsible for the following:-
 - Opening and closing of the ICT Lab and Smart class rooms for normal school hours except Sunday/Gazetted holidays in Himachal Pradesh
 - Day to day cleanliness, operation of hardware, software, other lab accessories, lodging of complaints and imposition of penalty for proper functioning.
 - To ensure that the trainings and refreshers of concerned subject teachers are carried out.
 - Concerned school Principal or his nominee will act as Assistant Nodal Officer (ANO) to ensure that the proper stock entry has been completed in all respect, checking the functional status of all hardware and allied

accessories during the contract period, ensure that the complaints regarding the defects has been logged in the complaint register and penalty has been imposed.

- The ICT lab will remain open during winter/Summer Vacations, if required. However, the Principal will ensure that UPS of ICT Lab and Smart Classrooms should be switched on at least once in a week for about 3 hours so that the batteries may not deep discharge.
 - The usage of these Smart Class rooms must be mentioned in Time table. He will ensure the usage of these smart class rooms.
 - He will be responsible for the stock entry of all the equipments and ensure the installation as per the implementation schedule.
 - He will be responsible for the payments to be made to the successful bidder after deducting the due penalty.
 - All the penalties will be imposed by him for faulty implementation/operation throughout the contract period.
 - To ensure that ministerial staff has been trained to use internet/e-mails and other relevant departmental/other software.
 - To ensure that correct entries are made on last working day in each month in online MIS. If the internet facility is not available in the school then the entry be made from nearby Cluster school or Dy. DHE Office on the scheduled date. Any lapse in this regard will invite disciplinary action against the concerned Principal.
- iv. Successful bidder will be responsible for compliance of all the statutory labour laws w.r.t. deployment of manpower by him under the contract and any/all liabilities accruing on account of labour laws will be the responsibility of the BOOT Operator.
- v. In case of any complaint regarding the services, the school Principal will inform the Nodal Officer/ office of Dy. DHE of the concerned Districts. The Nodal Officer will forward the complaints to the helpdesk/concerned engineer to resolve the problem within the given time frame. The helpdesk/engineer will report back to Nodal Officer after rectification. The bidder will supply telephone numbers alongwith address of SPO and resident engineer at district level to the concerned school Principals /Nodal officer/Dy. Director of Hr. Education/ Directorate of Higher Education. The bidder will also establish a helpdesk at Shimla (HQ) for attending the hardware failure calls. The complaint logged by the Principal should be clearly reflected in MIS software also.

9. Duration of Contract: Duration of contract would be 36 months. The contract period will commence form the day of successful delivery and installation of hardware, software and connected accessories.

10. Location of Schools: The Department reserves the right to carry out minor change in the location of the schools.

Table A- SPECIFICATIONS

<p>Line Interactive UPS</p>	<ul style="list-style-type: none"> • Capacity 650VA • Inverter Device MOSFET based • Rated Output Voltage 230 V(1-Phase) • Rated Output Current 2.8 A at 0.8 p.f. • Input Voltage Range 160-270 VAC • Input Frequency Range 50 Hz \pm 6% • Waveform quasi sinewave • Power Factor 0.65 lag to 0.8 • Output Frequency regulation (inverter mode) • Frequency regulation in Inverter Mode 50Hz \pm 0.5% • Overall Efficiency > 70% • Inverter Efficiency > 75% • Cold Start Feature • Charger capacity min. 2 amp • Overload Capacity 110% (for 30 sec) • Batteries SMF (VRLA) Type of reliable brand like Panasonic, Hitachi, • Exide or equivalent to provide 25-30 minutes backup(on single PC) • Min VAH : 168 VAH <p>Quality Standards</p> <ul style="list-style-type: none"> • ISO-9001-2000 Certified Safety Standards and EMC Standards as per IEC standards • The following formula will be used for calculating the VAH of batteries that is required. • Software option / Interface RS 232 port • RoHS Compliant
<p>Qty per School</p>	<p>2, if option A is exercised</p>
<p>Line Interactive UPS</p>	<ul style="list-style-type: none"> • Capacity 1000 VA • Inverter Device MOSFET based • Rated Output Voltage 230 V(1-Phase) • Rated Output Current 4.0 A at 0.8 p.f. • Input Voltage Range 160-270 VAC • Input Frequency Range 50 Hz \pm 6% • Waveform quasi sinewave • Power Factor 0.65 lag to 0.8 • Output Frequency regulation (inverter mode) • Frequency regulation in Inverter Mode 50Hz \pm 0.5% • Overall Efficiency > 70% • Inverter Efficiency > 75% • Cold Start Feature • Charger capacity min. 2 amp

	<ul style="list-style-type: none"> • Overload Capacity 110% (for 30 sec) • Batteries SMF (VRLA) Type of reliable brand like Panasonic, Hitachi, • Exide or equivalent to provide 50-60 minutes backup (on single PC) Min VAH : 336 VAH
	<p>Quality Standards</p> <ul style="list-style-type: none"> • ISO-9001-2000 Certified Safety Standards and EMC Standards as per • IEC standards • Software option / Interface RS 232 port
Qty per School	2, if option B is exercised
ON-LINE UPS with:	<ul style="list-style-type: none"> • True On-Line UPS with double conversion technology • Capacity 1 KVA/ 800 W • Rectified & Inverter Device IGBT based • DG Set compatibility • Rated Output Voltage 230 V(1-Phase) • Rated Output Current 3.6 A at 0.8 p.f. • Input Voltage Range 160-270 VAC • Input Frequency Range 50 Hz \pm 6% • Input Current THD < 15% • THD Output <7% for non-linear loads and < 4% for linear loads. • Voltage Regulation (Mains Mode) 230 V \pm 1% • Waveform pure sinewave • Power Factor 0.95 lag to unity • LCD display for ups status, load label, battery level, input /output voltage & fault condition • Output Frequency regulation • Free running Mode 50Hz \pm 0.5% • Sync Mode 50Hz \pm 2Hz • Crest factor for loads 3:1 • Overall Efficiency >85% • Inverter Efficiency > 90% • Cold Start Feature • Charger Type CVCC SMPS based • Overload Capacity 110% for 10 min 125% for 1 min • Batteries SMF (VRLA) Type of reliable brand like Panasonic, Hitachi, Exide or equivalent to provide 1 hr backup Min VAH : 1440 VAH • Quality Standards: ISO-9001-2000 Certified Safety Standards and EMC Standards as per IEC standards, should be capable of operating in eco-mode for energy saving • Software option / Interface RS 232 port /USB/ DB – 9 port: SNMP Compatible must support windows/linux/Novell/free BSD.
Qty per School	One
On line UPS	<p>ONLINE UPS with:</p> <ul style="list-style-type: none"> • True On-Line UPS with double conversion technology • Capacity 6KVA/4.8 KW • Inverter Device IGBT based • DG Set compatibility

	<ul style="list-style-type: none"> • Rated Output Voltage 230 V(1-Phase) • Rated Output Current 17.3 A at 0.8 p.f. • Switching Frequency >15KHz • Input Voltage Range 160-270 VAC • Input Frequency Range 50 Hz ± 6% • Input Current THD < 15% • THD Output <7% for non-linear loads and < 4% for linear loads. • No. of phases 1-Phase • Voltage Regulation (Mains Mode) 230 V +- 1% • Waveform pure sinewave • LCD display for ups status, load label, battery level, inout/output • voltage & fault condition • Power Factor 0.95 lag to unity • Output Frequency regulation • Free running Mode 50Hz ± 0.5% • Sync Mode 50Hz ± 2Hz • Crest factor for loads 3:01:00 AM • Overall Efficiency >85% • Inverter Efficiency > 90% • Cold Start Feature • Charger Type CVCC SMPS based • Overload Capacity 110% for 10 min 125% for 1 min • Batteries SMF (VRLA) Type of reliable brand like Panasonic, Hitachi, • Exide or equivalent to provide 1 hr backup Min VAH : 8064 VAH • Quality Standards: ISO-9001-2000 Certified Safety Standards and EMC Standards as per IEC standards • Software option / Interface RS 232 port / DB – 9 port : SNMP Compatible
Qty per Smart School	One
Qualifying Brands for all types of UPS	<ul style="list-style-type: none"> • The OEM should be ISO 9001:2000 certified. • The OEM should be ISO 14001 certified. • The OEM having cumulative turnover more than Rs. 250 Crores • in India in last 3 financial years from UPS business only. • RoHS compliant. • The OEM should have support office in Himachal Pradesh/India from Last 3 years.
Multimedia Education Content	As provided under scope of work
Qualifying criteria	The content developer/ company should have annual turnover of more than Rs. 1 Crores in last 3 financial years from multimedia educational content development.

**Desktop
Computers for
ICT Lab**

- The System with
- Motherboard branded for OEM or the Computer Manufacturer
- 4 PCI Slots (including minimum 1*PCIx16 slot)
- Intel Core i5-2400 @3.1 GHz or higher Processor/ AMD to meet
- SPEC CPU2006 benchmarked with SPEC rating in the range of
- at least 100 +/-5 with 4GB RAM (60% of SPECint_ratebase 2006
- plus 40% of SPECfp_rate_base 2006 score)
- 4 GT/s System Bus
- Intel H6x Series Express Chipset or better/ AMD 785G/ NVIDIA
- or higher
- 4 GB DDR3 RAM @1333 MHz Non ECC (Expandable up to 8 GB)
- 500 GB SATA Hard Disk Drive (7200 rpm) SMART.
- 16X or higher(SATA based) DVD-RW
- Integrated on M/B High Definition Sound AC97/ 20-bit audio
- (or equivalent)
- Integrated Intel extreme graphics on M/B/ Integrated onboard
- Graphics
- Integrated Serial ATA (3 Gbps) controller with 4 ports
- Integrated on M/B 10/100/1000 Mbps Ethernet controller with full duplex & WOL support
- Ports - 1xSerial, Rear: 6xUSB, Front: 2xUSB, 1xVGA & 1xRJ45,2xPS/2
- 18.5" LED backlit display colour monitor with maximum 0.3 mm dot pitch, TCO-05,1366x768, 1000:1 contrast ratio, 250 cd/m2, 5ms response time,160/160 degree view angle, VGA connectivity, EMI/FCC (or ETDC Report for meeting FCC norms)compliance, Energy star compliance same brand as that of PC.
- 104 Keys OEM English Keyboard (it must have soft keys), same brand as that of PC
- Optical Mouse of same brand as that of PC.
- ATX/BTX/Micro ATX/SFF Chassis with 1 x 3.5" & 2 x 5.25" front accessible bays , 2 x3.5" internal drive bays and adequate
- power supply

Manageability Features:

	<p>Asset Management: Gives summary of computer: BIOS, Disk Drives, Installed Applications, Memory, Motherboard, Slots, Multimedia, OS Information, USB Ports, Processor, System Resources, asset tag.</p> <p>Health Monitoring: Log entry for critical changes in Drive (Space), CPU Fan (Speed), CPU voltage, CPU Temperature. Automatic shutdown can be set when CPU temperature exceeds threshold limit.</p> <p>Security: Removable media boot control, serial, parallel and USB interface control, power on and setup password. Provision for external lock and Kensington slot (Desirable)</p> <p>Remote Management: Remote shutdown, Reboot</p> <p>Certifications:</p> <ul style="list-style-type: none"> • Designed for Windows 7. • Linux Ready • Energy Star 5.0/BEE Star for the quoted model • UL, FCC (EMI EMC) certified • PCI 2.3 compliant • ACPI 1.0 compliant • IPV6 compatible • ROHS Compliant
Qty per school	Two
Qualifying Brands	<ul style="list-style-type: none"> • Reputed OEM having annual turnover more than 800 Crores in India in last 3 financial year. • ISO 9001: 2000 certification for design, manufacturing and services. • ISO 14001: 1996 certification for environmental standard, • The OEM should rank in top 10 brands by IDC in India
Laptop	<ul style="list-style-type: none"> • The System with • Intel Core i3 2350 @2.10 Ghz Processor or higher • MB L3 Cache • 5 GT/s System Bus • Intel HM65 Express chipset • GB DDR3 RAM expandable upto 8 GB. • 500 GB SATA Hard Disk Drive (5400/7200 rpm) • Integrated 8x DVD+/-RW drive • Integrated HD Graphics 3000/NVIDIA GeForce 410GM CPU or better • media card reader • USB 2.0 or latest e-SATA HDMI, Microphone in, Stereo • headphone line out, RJ-45, • cell Li-Ion BATTERY WITH ADVANCE MANAGEMENT • 10/100/1000 Mbps ethernet controller

	<ul style="list-style-type: none"> • Intel High Definition Audio. Internal stereo speakers, • 13"/14" LED backlit display(1280x 800 or 1366x768 WXGA) • with HD webcam • Integrated 802.11 b/g/n wireless LAN connection, Bluetooth • v3.0+ • Carry case • Energy Star 5.0 or higher for the quoted model. • IPV6 compatible • Weight less than 2.4 kg including battery. • ROHS Compliant
Qty per Smart Class room	One
Laptop	<p>The System with</p> <ul style="list-style-type: none"> • Intel Core i5-2520 @2.5 GHz Processor or higher • MB L3 Cache • 5 GTP/s • Intel HM65 Express chipset • GB DDR3 RAM expandable upto 8 GB. • 500 GB SATA Hard Disk Drive (7200 rpm or higher) • Integrated 8Xor higher DVD+/-RW drive • Integrated HD Graphics 3000 or better • media card reader. • 6 cell Li-Ion Batter with advance management features • 10/100/1000 Mbps Ethernet controller • Integrated Speakers • USB 2.0 port, e-SATA HDMI, Microphone in, Stereo headphone line out, RJ-45 • 13"/14" LED backlit display(1280x 800 or 1366x768 WXGA) • with HD camera • Integrated 802.11 b/g/n wireless LAN connection, Bluetooth • v3.0+ • Carry case • Energy Star 5.0 or higher • IPV6 compatible • 3 Years comprehensive onsite warranty. • Weight less than 2.4 kg. • ROHS Compliant
Qualifying Brands	The OEM should have a minimum annual turnover of Rs. 250 Crores in each of the last 3 financial years from laptop business only
Total Quantity	19

Technical Specifications for Shared Computing System	Access Device : Allow (1+4) users to share a single host Through a shared Computing PC-Sharing kit(which includes one Full Height PCI Card,Virtualization software, and 4 access devices with Speaker Output, PS/2 Mouse and PS/2 Keyboard Output. Monitor output and RJ 45 Connection Port. Each access device should be standalone equipment and not integrated with any peripherals like keyboard, mouse, monitor etc
	Monitor : Each user should have independent Monitor:18.5" LED backlit display color monitor with maximum 0.3 mm dot pitch, TCO-05, 1366x768,1000:1 contrast ratio, 250 cd/m2, 5ms responsetime,160/160 degree view anger, VGA connectivity, EMI/FCC (or ETDC Report for meeting FCC norms) compliance, Energy star compliance same brand as that of PC. The access device should be integrated with host PC via UTP cable
	Keyboard : PS/2 104 Keys keyboard same brand as that of PC
	Mouse: PS/2 Optical mouse same brand as that of PC
	Log-in & Log-out: Login Experience, Responsiveness (mouse, keyboard, application start - up and execution).Graphics/Multimedia, Logout
	Power consumption : Power consumption of each access device should not exceed more than 1-2 watts
	Each user should have independent desktop environment
	Following O/sandothertobe Supported: MS Windows OS XP/Vista/7 & Server2003/2008,Windows Server 2008 R2, Windows Multipoint Server 2010,2011) and Linux.(Ubuntu)
	Office Suite (MS), Internet and other software's viz., Flash based Multimedia applications.
	Peripheral Ports : VGA, PS/2 Mouse, PS/2 Keyboard and Speakers
	Connection overview : 1) Speaker Jack (2) PS/2 Keyboard Port (3) PC/2Mouse Port (4) VGA Monitor Port (5) RJ-45 PCICard Connection Port
	Distance from Host PC : Maximum 20 feet
	Cable Length : Standard Category 6 UTP Cable: upto 5 meters(16 feet), 6 STP Cable: upto 10 meters (33 feet).
	Audio : 16 bit stereo output via speaker port
No. of Users per kit: 1+4 users to one Kit	
Connection Type : Direct UTP Cable	

	<p>Cat6 UTP Patch cords : Factory Crimped with RJ 45 jacks on both the ends of Cat6 STP Cable of 5Mtrs length or Actual Host Terminal. Should not increase more than 10Meter or 32 ft</p> <p>Certifications : ISO 9001, FCC Class B, MIC, RoHS Compliant</p> <p>External Speakers : Pair of external Speakers, same Make of PC</p> <p>Warranty: Virtualization Software should support current operating system and for another five year for latest Provided by Windows & Linux (Ubuntu)</p>
Qualifying Brand	The OEM/bidder should have provided above mentioned shared computing solution at least in 1000 Govt. Offices/Institutions/Schools or 5,000 seats in India in last 3 years. Bidder has to provide manufacturer "authorization letter for Proposed Solution for Shared Computing.
	The proposed solution should support any new patches, Upgrades/ version releases, migrating from Open source to Microsoft platform or vice versa or both in case dual boot operating system as an when department request.
	Only one technology option would be permitted to be quoted by each bidder, in case of shared computing solution
Qty per school	8 access device, 2 PCI cards
Printer/copier/scan/ fax	Multi Functional Laser Printer with facility of print, scan, copy and Fax; Print Speed 16 PPM, Resolution: 600x600 dpi (1200 DPI effectiveoutput), 64 MB RAM, 150 sheet fed tray ; Fax speed 33.6 Kbps, auto redialing, Scanner: Flatbed & 30 sheet fed ADF, Processor Speed :386Mhz or higher , Hi-Speed USB 2.0 or better, display LCD, 10/100 Base-T Ethernet network, copier resize 25 to 400%, copy speed upto 18cpm; Power Consumption: less than 390W in active mode, less than5W in stand by and less than 0.05W in off mode; Energy Start qualified.
Qualifying Brands	OEM having annual turnover more than 200 Crores in last financial year in India.
	OEM should have supplied more than 2000 units in India directly or through partners.
Qty per school	One
LCD Projector	<p>Feature - Specifications</p> <ul style="list-style-type: none"> • Resolution - 1280 x 768 WXGA • Brightness - 2500 lumens or higher • Contrast ratio - 2500:1 or better • Zoom/focus - Manual focus & zoom (1.2:1) • Picture size - 40-300 inches diagonal

	<ul style="list-style-type: none"> • Wall color control - Beige, blue, green, pink, blackboard, whiteboard • Lamp life - 6000 hrs or better • PC compatibility - LAN Port, 2x USB Port • Video compatibility - NTSC, PAL-M, PAL-N, DTV, HDTV (480i, 480p, 575i, 575p, 720p, 1035i & 1080) or better. • Input terminals - RGB: Mini D-sub 15pin x 2 • Output terminal - Audio: Stereo Mini Jack (ø 3.5mm) x 2(One for PC, another for Video)Video: RCA x 1 & S-VIDEO x 1Audio: RCA (LR) x 1RGB: Mini D-sub 15pin x 1 • Sound Output - Audio: Stereo mini jack (ø 3.5mm) x 110W or better • Fan Noise - 35db/28db or better • Comm. terminal - RS-232C , LAN (RJ-45) x 1 • Power requirements - AC 100-240v, 50/60 Hz • Lamp Hour Counter - In-built • Remote - Full Functional Remote Control • Keystone Correction - Auto Digital
Qty per school	Two
Qualifying Brands	OEM having annual turnover more than Rs. 150 Crores in last three financial year in India
Integrated Computer Projector	<ul style="list-style-type: none"> • Projection System: DLP Technology • Brightness: 2500-ANSI Lumens (Short Throw) • Resolution: WXGA (1280x800) • Contrast Ratio: 2500:1 • Computer System : Intel Core i3 Processor, with Integrated graphics, 2 GB DDR III RAM, 320 GB Serial SATA II 7200 RPM HDD, Optical Drive DVD RW, Wireless Keyboard & optical Scroll Mouse • Input: PS/2 Mouse & Keyboard, RF-in for TV, USB ports, Microphone in • Output : Internal 30 watts Audio Output, LAN: 1x Gbps LAN, • Integrated analogue cable TV tuner
Qualifying Brands	OEM Should have annual turnover more than 25 crores in last three financial years in India
Qty per school (For Smart class rooms)	Two
Interactive White Board	<ul style="list-style-type: none"> • Active Size: Minimum 77/78” diagonal • Board surface: Scratch resistant surface; maintenance free • Operating System: Window 98, 2000, ME, NT, XP, Vista, Windows 7 or higher and Linux • Aspect Ratio: 4:3 • Writing Tools: Pen/ stylus/ finger • Active Area: Minimum active diagonal length of 1700 mm • Resolution: 4096*4096 • Position Accuracy: ± 0.2 mm • Power Options: only through PC/Laptop/USB

	<ul style="list-style-type: none"> • Technology: Touch resistive/Digitizer technology • Data ports: USB • Connectivity and Usage: Can be used individually and in conjunction with interactive pads and interactive panel • Storage: Saving of files in PC/Laptop • Software: Should have interactive features like palm touch, OCR, image gallery, image enlarge; snap shots, recording lectures, reveal option, Bilingual (English/Hindi) menu software etc. • Accessories: Stylus/ Pens, USB Cable, Software CD, user manual etc. to be a part of standard supply
Qty per school	Two
Qualifying	OEM/Indian distributor having cumulative turnover more than 15 Crores in last three financial years in India and must have supplied the device in atleast 100 Govt. Institutions (School, Colleges and Universities) and Offices in India.
	OEM should possess ISO Certification or equivalent IS/International standards.
LAN Equipment for ICT Lab and Smart Schools	8/16 Port Smart Switch with loop back detection, 16/24 Port CAT6 Patch Panel full loaded, Necessary cables to connect access device/terminal to desktop computer as per requirement
Qualifying Brands	D-Link/DAX/Cisco/HP/HCL
Web Camera	<ul style="list-style-type: none"> • HD Video calling (1280 X 720 pixels) with recommended system • Video capture: Up to 1280 X 720 pixels • Photos: Up to 5 megapixels (software enhanced) • Built-in mic Hi-Speed USB 2.0 certified (recommended) • Universal clip fits laptops, LCD monitors • Video and photo capture
Qty per school	One
Integrated Classroom Equipment/ Multi-Feature Device with Computing & Image Projection with in-built Interactivity	Computing
	Industrial grade 4th Gen Intel Based mini ITX Motherboard 4th Generation Intel core i3 processor, 3.4 GHz Dual-channel DDR3 with 2 connectors for 1600 MHz memory support 4GB DDR3 (expandable upto 16GB), 2 x 204 pin SO-DIMM connectors 64 Mb Flash EEPROM 500 GB mSATA
	Networking
	3G capability with built in SIM/UIM slot FRU IEEE Standards Compliance : GSM GPRS / EDGE, HSPA+Max Data speed : HSDPA → 7.2 Mbps; HSPA+ → 21 Mbps Operating Frequency : Quad band GSM – 850, 900, 1800, 1900 MHz; 3G – 850, 900, 2100 MHz
	Switching : 4 LAN/Ethernet (RJ-45) 10/100/1000 Mbps for LAN ,RF: 2.4 Ghz, 1 RJ-45 Uplink
	WiFi Wireless: Wireless LAN 802.11 b/g/n wireless access point 30 wireless capability support 4 Antennas (2 per band) WiFi Protected Access (WPA / WPA2 Personal), WEP, Wireless MAC filtering, Stateful Packet Inspection (SPI) firewall
	Image Projection, Camera & Video
	DLP Technology

Screen: 8*6 ft
Pixels: 786,432 pixels (H1024*V768)
Resolution: 1024*768 color pixels (XGA), 720 p
Contrast Ratio: 15000:1
Brightness: 3000 ANSI Lumens
LC Panel: .63 type (inch), 1.6cm polysilicon active-matrix TFT
High-efficiency lamp that last up to 6000 hours
projection lamp replacement FRU based
Manual Zoom x1.2
Camera
Pair of Camera
720p HD video (up to 1280 x 720 pixels)
Fluid Crystal™ Technology
H.264 video compression
Carl Zeiss® lens with 20-step autofocus
Automatic low-light correction
Hi-Speed USB 2.0/3.0 certified
Video
Multipoint video
30 Frame per sec
Codec H.264
Audio: Speakers and Microphone
Two Numbers of stereo front speaker (20 Watts RMS per channel (2 channels)
Wireless Microphone
Speakers
Power Management
AC Input Voltage 90-260V
Line Frequency 50-60Hz
Consumption < 295 Watts
Power on/off switch
Power Saving Mode
Physical and Environment Specifications
Physical Dimensions - Ceiling Mounted Chassis
Operating Environment - Operating temperature 0°C – 40°C
Operating Humidity - 10 to 80%, relative humidity, non-condensing
Storage Temperature - -20°C to 60 °C
Storage Humidity - 5 to 90% non-condensing
System Stability and Monitoring
Physical Reset Button
Touch Screen Pen (Stylus)
Software Compatibility
Microsoft Windows 7 Professional Edition SP1

	Support for advanced configuration and Power Interface (ACPI)
	Open Architecture, Plug and Play
	Collaboration Software for multiple device connection (PC, Laptop, Tablets, Mobile Handheld)
	Interfaces
	4 USB 3.0 ports, 2 USB 2.0 ports
	1 High Definition Multimedia Interface (HDMI) v1.4a, 1 VGA Conn
	1 Mic in, 1 Line Out Speaker
	4 RJ-45 LAN Ports, 1 RJ-45 Uplink Port
Qualifying Brands	OEM Should have annual turnover more than 25 crores in last three financial years in India
Qty per school (For Smart class rooms)	Two
Softwares for ICT Labs	The bidder has to provide following software licenses for 54 users for remaining users software licenses will be provided by the Department
	Windows Multipoint Server Premium 2011 SNGL OLP NL Academic OS for Servers
	<ul style="list-style-type: none"> Clients for MultiPoint Server Partner in Learning Program (PIL) includes Windows with 5 Yrs updates & Upgrades, MS Office Professional 2010, Visual Studio 2010 Professional, Encarta AE latest Version (downloadable)
Qty	54 users License
Software's for Smart Class Rooms	<ul style="list-style-type: none"> The bidder has to provide following software licenses for 108 users for remaining users software licenses will be provided by the Department PIL Programme Partner in Learning Programme (PIL) includes windows upgrades latest version upgrades, MS-Office with five years updates and upgrades Windows 7 starter OEM pack warranty.
Qty	108 User License
Software for Filtering/ Blocking of unwanted contents	Antivirus and Antispyware Antispam, File Encryption ,Two Way Firewall, , Anti-Phishing, Silent Mode, Gamer Mode, Setting Protection, Active Virus Control, Password Manager, Hourly update, Monitor Internet Activity , Filtrng Personal Data filter/ unwanted content Monitoring Screenshots, Keystrokes, Application Activity, Chat Activity, Clipboard Activity Reporting User Wise, User Login File Transfer logs Tamper Proof Blocking

	<p>USB ports, IEEE1394, Network Adaptors, CD/DVD, Printer, Infrared, Bluetooth, port when system idle, Single/All Ports, Whitelisting of authorized USB devices</p> <p>Website,</p> <p>Other Features</p> <p>USB read-only feature, Email Filtering, Laptop /Employee Tracking, Automated Data Encryption, Hardware & Software Tagging, Hardware & Software Tracking</p> <p>Monitor RAM & CPU Usage, Early warning for HDD failure, Disk Scanning/Cloning</p>
Qualifying Brands	<p>OEM Should have annual turnover more than 50 crores in last three financial years in India</p> <ul style="list-style-type: none"> ➤ The bidder will transfer all the software licenses under the name of the department as desired by the procuring entity during the exit management period. ➤ The software should be compatible with Windows Multipoint Server Premium 2011 SNGL OLP NL Academic OS for Servers
Creativity in Learning Program	<p>Software licenses for Adobe Acrobat XI Pro, Adobe Photoshop Elements & Premier Elements, Adobe Flash Professional, Adobe Presenter</p>
Qualifying Brands	<ul style="list-style-type: none"> ➤ OEM Should have annual turnover more than 50 crores in last three financial years in India ➤ The bidder will transfer all the software licenses under the name of the department as desired by the procuring entity during the exit management period. ➤ The software should be compatible with Windows Multipoint Server Premium 2011 SNGL OLP NL Academic OS for Servers.

The comprehensive warranty period for all equipment's/hardware/peripherals will be upto contract period.

The following components should have single brand to have uniformity:

- 1) **Desktop Computer /CPU/TFT Monitor/Mouse/Keyboard**
- 2) **6KVA/1 KVA online /1 KVA Line Interactive**

Furniture and Fixtures

Fixed Table assembly for ICT Lab:

Sr. No.	DESCRIPTION OF ITEM
1	Supply of tile based modular workstations of overall height 1089mm as per layout with following specifications and provisions
(a)	Framework:
	Supply of workstations in tile based modular partition system of overall thickness shall be 56mm. The frame shall comprise of 2 vertical uprights, a top horizontal tube and a bottom C channel as a welded structure. The vertical upright shall be made from 1.5mm thick CRCA M.S. Grade D formed into "C" channel of 28.4 X

i)	<p>40. The top horizontal shall be 1.2 mm thick M.S. tube of 38.1 X 25.4 mm (1 X 1 ½ inch). The bottom horizontal shall be 1.5 mm thick M.S. “C” channel of size 38.1mm x 25.4 mm (1 ½ in x 1 in). The frame shall be powder coated in standard black colour. The vertical upright shall have 4 side slots of size 60mm H X 10mm W, for passage of cables through out the width of the panel. The bottom horizontal shall have 2 slots of size 100mm L X 20mm W for entry of cables into the system. The vertical upright shall have front slits for fixing work surface brackets at a pitch of 25.4mm. To avoid passage of light through the horizontal gap of 4.4mm between the tiles, a 0.8mm the M.S. CRCA Grade D, black powder coated C shaped light barrier shall be riveted to the frame. The light barrier shall have three slots of size 75 X 15mm for the wires to pass through.</p>
ii)	Frame Joinery
	The frames shall be joined to each other with the help of 2 way, 3 way and 4 way joineries with the help of universal connectors at the junction of the frames. The universal connector shall be screwed to the frame using M6 X 30 long socket button head cap screws.
iii)	Trims
	Powder coated aluminum alloy (of grade He-9 – 63400) Flat trims of 53.5mm X 13mm and average wall thickness of 1.2 mm shall be fitted on the top horizontal using M6 X 55L bolts & Nut and the open vertical ends of the upright using M6 X 25L Bolt & Nut. The open vertical joinery for the configuration 2 way and 3 way shall be covered with 2 way and 3 way aluminum alloy (of grade He-9 – 63400) vertical trims of 1.2mm average thickness, which shall be powder coated and press fitted onto the universal connector made of 2mm th M.S. All the joinery shall be finished with diecast powder coated Mazak flat caps.
iv)	Prelaminated fins
	Prelaminated fins as end partitions shall be 25mm th made of plain particle board finished with laminate of approved shade and color and edge banded with hot pressed PVC lipping. The same shall be fitted to the main panel with the help of fin extrusions
b)	Tiles:
i)	Fabric tiles: Fabric shall be upholstered on metal tiles in 0.6 mm thick M.S. CRCA Grade D as per IS:513-1994
ii)	Plain Metal tiles: It shall be powder coated metal tiles in 0.6 mm thick M.S. CRCA Grade D as per IS:513 - 1994.

(c)	Worksurfaces:
i)	Rectangular work tops of sizes 1049mm w x 599mm d shall be made of 25mm thick Prelaminated particle board interior grade of approved shade conforming to IS:12823:1990. Bottom shall have a backing laminate of minimum 0.6 mm thickness. All the edges of work surface shall be provided with machine pressed 2 mm thick PVC lipping glued with hotmelt EVA glue
ii)	The worksurfaces shall be mounted on the 13 inch worksurface bracket of 2.5mm thick M.S.. Side panels shall be attached to the upright using the side panel brackets. All the above brackets shall be powder coated.
(d)	Workstation should be provided along with CPU Holder. Metal component of Holder shall be finished with powder coating
(e)	Workstation should be Green Guard Certified/IGBC (Indian Green Board Certified)
	<p>Wooden cabinet for Smart Classrooms</p> <p>Overall Size of table should have 1000L*600W*750D.The table should have Horizontal width of 555 mm which is required for housing key board pull out tray and should be between two side panels. There should be overhang on table top required on both side with size of 15 mm. The Clear horizontal width inside for CPU chamber 180mm. The Clear horizontal width inside for UPS chamber shall be 178 mm. The above specification is required considering 18 mm prelam practical board PLT side panel. Lockable KBPT considered is Lockable Wooden keyboard pullout tray. The table should adhere to the image given. Manufacturing tolerance will be allowed as (+/-5%) as per industry norms</p>
Qualifying Brands	<ul style="list-style-type: none"> • The manufacturer / Companies should have its own office or its associates in Himachal Pradesh or North India from last one year to ensure proper after sale service • The Company should have toll free No. for immediate action in case of any post-delivery issue in the product. • Company should have completion of more than 3000 No's Multilocation Govt. Sites • Manufacture/company must have annual turnover more than 300 Crores in last financial year in India.

	<ul style="list-style-type: none"> • The manufacture/company should be ISO 9001:2008, ISO 14001, BIFMA and Green Guard certified//IGBC (Indian Green Board Certified
PVC Flooring	
Sr. No.	Sub-Head & Items of Work
1	Providing and fixing 2mm thick PVC/Rubber flooring plain. Colored /Corbel or mosaic or matted or wood pattern finish, laid with approved adhesive. Wherever a minor repair is required for leveling the floor the same may also be carried out.
Qualifying Brands	<ul style="list-style-type: none"> • The manufacturer should have annual turnover more than 300 Crores in last three financial years in India. • The bidder will have to approve a sample of 2x2 feet from the department before delivery and installation.
Seating arrangement for Students: Chairs	
Sr. No.	Sub-Head & Items of Work
1	PVC/Plastic moulded 30 Chairs (Make: Supreme, Model: Lily or Nilkamal make, Model:CHR4001) per school without arms rest
Qualifyin g Brands	The bidder will have to approve a sample of the product from the department before delivery and installation.

Electrical Wiring and equipment's Earthing

- Copper plate earthing stations making earthing with copper earth plate 600 mm x 600 mm x 3 mm thick including funnel, char-coal/coke, salt, all earth work. The earthing should be 4 feet deep or more.

Wiring (All equipment's/ appliances /fittings should be ISI/ISO certified)

Section III - Instructions to Bidders

1. Definitions

In this document, the following terms shall have following respective meanings:

- I. **"Agreement"** means the individual contracts to be signed between the successful bidder and the Department of Higher Education, for Scope of work for 1450 Government Schools, 5 Smart Schools and 70 newly upgraded Government Schools, including all attachments, appendices, all documents incorporated by reference thereto together with any subsequent modifications, the tender document, the bid offer, the acceptance and all related correspondences, clarifications, presentations.
- II. **"Smart Class Room"** means the room where Interactive White Board, CPU, UPS, Mouse and keyboard have been installed.
- III. **"Authorized Representative"** shall mean any person duly and formally authorized by either of the parties.
- IV. **"Bidder"** means a corporate firm / organization/ company / corporation/ society registered/incorporated in India eligible to bid in the stages of pre-qualification, Bidding process and shall include the successful bidder during the currency of the Contract.
- V. **"BOOT model"** the services as required by the Tenderer are specified in Schedule of Requirements on Build, Own, Operate and Transfer (BOOT) model.
- VI. **"Contract"** is used synonymously with Agreement.
- VII. **"Corrupt Practice"** means the offering, giving, receiving or soliciting of any thing of value to influence the action of an official in the process of Contract execution.
- VIII. **"Fraudulent Practice"** means a misrepresentation of facts in order to influence bidding process or the execution of a Contract and includes collusive practice among Bidders (prior to or after Bid submission) designed to establish Bid prices at artificial non-competitive levels and to deprive the Department of Higher Education of the benefits of free and open competition.
- IX. **"ICT Lab"** means Information & Communication Technology lab, located inside the School premises.
- X. **"Smart Class rooms and ICT lab working days"** means all the days including School working days, vacation days and days on which the School Principal decide to keep the lab functional.
- XI. **"Smart Class rooms and ICT lab working hours"** normally would mean 9.00 AM-4.00 PM for School subject to any variation as may be decided by the School principal from time to time.
- XII. **"Implementation Period"** shall mean the period from the date of signing of the Agreement i.e. 120 days.
- XIII. **"Law"** shall mean any Act, notification, bye law, rules and regulations, directive, ordinance, order or instruction having the force of law enacted or issued by the Central Government and/ or Government of Himachal Pradesh or the Department of Higher Education, Government of Himachal Pradesh or any other Government or regulatory authority or political subdivision of government agency.
- XIV. **"LOA"** means issuing of Letter of Award, which shall constitute the intention of the Tenderer to place the work order with the successful bidder.

- XV. "Party"** means the Department of Higher Education or Bidder, individually and "Parties" mean the Department of School Education/Department of Higher Education and Bidder, collectively.
- XVI. "Proposal"** means the Pre-qualification, Technical Proposal and the Financial Proposal.
- XVII. "Requirements"** shall mean and include schedules, details, description, statement of technical data, performance characteristics, standards (Indian as well as International) as applicable and specified in the tender document.
- XVIII. "School Working Days"** means all days declared as working days by Department of Higher Education, Government of Himachal Pradesh.
- XIX. "Site"** shall mean the location(s) for which the Contract has been issued and where the service shall be provided as per agreement.
- XX. "Service"** means provision of Contracted service viz., operation, maintenance and associated services for Information and Communication Technology (ICT) Project as per this tender document.
- XXI. "Tenderer"** means the Department of Higher Education, Govt. of Himachal Pradesh, who is issuing this tender.
- XXII. "IT/ICT related Services/ Activities"** means supply, installation, maintenance of Computer, IT education, ICT/IT trainings.
- XXIII. "Last three financial years"** means 2010-11, 2011-12 and 2012-13.

2. Eligibility Criteria

- 1) The bidder should have existence in India for the last three financial years. Consortium bidding of only two (i.e. Prime Bidder + One Company) companies will be allowed.
- 2) The bidder should be in profit for the last three financial years.
- 3) The bidder must bid for entire scope of work.
- 4) The bidder should have overall turnover more than Rs. 300 Crores in the last three financial years in India.
- 5) The bidder should have turnover more than 150 Crores in IT/ICT/ICT related activities in India in last three financial years.
- 6) The bidder must have trained atleast 1500 Govt. Institutions teachers in the last three years. The bidder should have well established and proven methodology of conducting teacher training.
- 7) The bidder must have implemented/implementing IT/ICT in at least 500 Govt. Institutions in India in last three financial years.
- 8) The bidder should have supplied multimedia educational content in atleast 200 Institutions in India in last three years.

3. General Conditions:-

- 1) The bidder should have substantial presence in Himachal Pradesh. In case bidder has no presence in Himachal Pradesh, bidder shall furnish an undertaking that an office shall be opened in Himachal Pradesh, with comprehensive support services including sufficient personnel within a month of selection as Successful Bidder.
- 2) Any equipment including hardware/software's/infrastructure once installed will become the property of Department of Higher Education /Government of Himachal Pradesh.
- 3) **The department can change and amend the terms and condition of tender or can cancel the tender at any stage (point of time) without specifying any reasons.**
- 4) The bidder should not be involved in any dispute with the Department of Higher Education in any education related projects in Himachal Pradesh. The bidder will submit the declaration (on affidavit) in this regard. If found violative at any later stage, the department reserve the right to cancel the agreement and all the infrastructure installed in the School will become the property of the Government of H.P. and no payment due of any kind will be made to the bidder.
 - a. **In case the company deviates from the provisions of Tender document/agreement during implementation of the project in any school, the Govt. shall have the right to instruct the bidder to**

provide the required services in the school(s) as per the terms and conditions of the tender document/agreement. If the bidder deviates from the provision of Tender document in 15% or more allotted schools, then the agreement will be cancelled and the Bank Guarantee will be invoked and entire infrastructure will become the property of the Govt.

- b.** Watch and ward will be the responsibility of the concerned school. In case the company already doing such job in the H.P. State under earlier tender is found to be lowest bidder, the contract shall be awarded to such company subject to the following conditions:-
- i. That it has fulfilled all the terms and conditions of the earlier tender and no clause remained to be implemented.
 - ii. That no court case/ dispute between the company and the department or between the company and its master franchisees, regarding faulty implementation of the earlier contract pending in any court of law.
 - iii. That the terms and conditions of the previous tenders and MOU/any decision taken there under in relation to that document will not be applicable to the present Tender Document in any form.
 - iv. The Companies already executing similar projects pertaining to ICT/IT Education in Schools will not use the services of their existing staff.

4. Implementation Schedule:

- The bidder has to start the execution of the project immediately after the signing of the agreement and has to submit the total contents well before 120 days after signing the agreement.
- The bidder will have to submit weekly progress report of work assigned (as per tender document and agreement) from the signing of the agreement.
- The bidder has to establish one sample site in any of the allotted school for inspection/quality check and verification of quated brands as per Annexure-N, with in 30 days after the date of signing of agreement.
- The bidder has to complete all liabilities covered under the scope of work in the total allotted schools within 120 days after the signing of the agreement.

Non-completion of work assigned will invite imposition of penalty as per section 3 clause 16.

5. Bid Documents

Bidders are expected to examine all instructions, forms, terms, and

requirements in the bid document. Failure to furnish all information required by the bid document or submit a Bid not substantially responsive to the bid document in every respect may result in the rejection of the Bid. The bids should be submitted in two parts as mentioned hereunder:

A. Pre-qualification Bid as per eligibility criteria specified

- i. A letter on the bidder's letter-head including the undertaking for acceptance of bid terms as per format provided in **Appendix –“A”**
- ii. The EMD **for Scope of Work: Rs 30 Lacs** (Thirty lacs only) in the form of a Demand draft issued by a Nationalized Bank, drawn in favour of Director of Higher Education, Himachal Pradesh payable at Shimla (**to be enclosed with the Pre-qualification bid**). No other form of EMD will be accepted.
- iii. Tender Fee of **Rs. 10,000/-(Ten Thousand Only)** in the shape of Demand Draft issued by a Nationalized Bank, drawn in favour of Director of Higher Education, Himachal Pradesh payable at Shimla. (**To be enclosed with the Pre-qualification bid, if not attended the pre bid conference**)
- iv. Details of the Bidder organization as per format provided in **Appendix - “B”**.
- v. Attested copies showing the legal status, place of registration and prime place of business of the bidder
- vi. Certified Copy of Certificate of Incorporation and Memorandum and articles of Association of Bidder.
- vii. Bidder will submit the attested copies of Sales Tax / VAT Registration/PAN/TAN No and Sales Tax / VAT returns filed in the last financial year.
- viii. Bidder need to furnish financial tie-up details such as source of funds, comfort letter from banks/ FIIs, etc. at the time of submission of their bids for project funding. In case project funding is proposed through internal accruals/funds, bidder is required to submit a declaration for the same on bidder's letter head.
- ix. Bidder will submit attested copies of acknowledgement of Income Tax returns filed in each of the last three financial years
- x. Bidding Company will submit attested copies of Audited financial Statements clearly indicating the overall and IT/ICT and related turnover for last three financial years Certificate from a Chartered Accountant as per **Appendix-“C”** showing the firm's:
 - a. Total turnover & Annual Turnover in IT/ICT/ICT related activities in the past three financial years.

- b. Profitability (Profit After Tax) over the past three financial years
- XI. Power of Attorney of the Bidder appointing a designated/ authorized person for signing the bid/contract.
- XII. Documentary proof of having trained 1500 Govt. Institution teachers in last three years (copy of the agreement signed with State Govts/Deptts/ Educational Institutions be enclosed). **Appendix –“D (a)”**
- XIII. The bidder must have implemented/implementing IT/ICT in at least 500 Govt. Institutions in India in last three financial years. (Copy of the agreement signed with State. Govts/Deptts/ Educational Institutions be enclosed). **Appendix –“D (b)”**
- XIV. The bidder should have supplied multimedia educational content in atleast 200 Institutions in India in last three years. (Copy of the agreement signed with State. Govt./Deptts/ Educational Institutions be enclosed). **Appendix –“E”**
- XV. Documentary proof of having authorization from Original Equipment Manufacturer (OEM) for supply, installation and maintenance of hardware/Manufacturers authorization form(s).
- XVI. A copy of the Tender Document, all pages duly signed by the authorized signatory towards acceptance of the terms and conditions of the Tender Document. Only one signed copy to be annexed with original pre-qualification bid.
- XVII. Bidder need to provide documentary evidences wherever applicable.
- XVIII. Bidder will submit the Audited financial Statements clearly indicating the annual turnover & other relevant documents/agreements as experience proofs as required in respect of the items covered in the **Table-A, Technical Specification**
- XIX. The successful bidder will have to get registered with HP Excise & Taxation Department under HP VAT Act for local billing.

B. Technical Bid

The technical bid will comprises of the following:

The bidder shall submit the DVDs of Multimedia Educational Contents on the following topics in the Technical Bid in following manner:

S.No.	Subject	Class	No. of topics
1.	Mathematics	10 th	1
2	English	10 th	1
3.	Science	10 th	1
4.	Social Science	10 th	1
5.	Hindi	10 th	1
6.	History	11 th	1
7.	Accountancy	12 th	1
8.	Business Studies	12 th	1
9.	Mathematics	12 th	1
10	Physics	12 th	1
11	Chemistry	12 th	1
12.	Geography	12 th	1
13.	Biology	11 th	1
14.	English	11 th	1
15	Economics	11 th	1
	Total		15

This set of multimedia educational content shall not be returned in any case and shall become property of Govt. of Himachal Pradesh. The content so submitted in the bid will be on the same topics for all the bidders.

The bidder has to submit the usage rights of the above mentioned 15 multimedia educational contents. The bid will be rejected, if the following topics are not submitted in the technical bid.

The bidder shall submit the Multimedia Educational Content in the Technical Bid in following manner:

All DVDs must be labeled appropriately clearly stating the subject and the classes

The bidder must submit an undertaking that the client's will have the Intellectual Proprietary Rights (IPR) & Source Code of the solution / product/ solution, so developed, within framework being offered under this

TENDER. List of topics is annexed as “**Annexure-L**”

C. Commercial Bid-ICT in Govt. Sr. Sec. Schools under Department of Higher Education

Commercial offer as per “**Appendix-F**”.

6. Sub-Letting of Contract

In no case the successful bidder shall be allowed to sublet this project either wholly or in parts, to any sub-contractor/ sub-franchisee at any stage. In the event of bidder contravening this condition, the contract shall be terminated with immediate effect and bank guarantee shall be invoked and the entire infrastructure installed like instruction material, equipments, software, hardware, furniture, and site installation etc. would become the property of Government of Himachal Pradesh.

7. Pre-bid Conference

- a. Bidders may note that a pre-bid conference will be held on 18-03-2014 at 2:00 PM in the Conference Room, Directorate of Higher Education, Lalpani, Shimla-1. The interested bidder(s) shall have to get registered in the o/o Jt Director of Higher Education (C-I), Directorate of Higher Education on 18-03-2014 from 10:00 AM to 1:00 PM. The interested bidder(s) shall furnish an EMD of Rs 30 Lac only in the form of a Demand draft issued by a Nationalized Bank located in India, drawn in favour of Director of Higher Education, Himachal Pradesh payable at Shimla and the Tender Fee of Rs.10,000/- in the shape of demand draft drawn in favour of Director of Higher Education, Himachal Pradesh, payable at Shimla at the time of registration. Only registered parties will be allowed in pre-bid conference. The EMD of the participants will be returned on the same day after the pre-bid conference on the request of the participants. No interest of any kind will be paid on the EMD of the participants. The Bidders will have to submit their queries through FAX or email required to be discussed in the pre bid meeting on or before 14-03-2014 upto 5:00 PM. The clarification of the queries would be uploaded on the website **www.educationhp.org**. Bidders will have to consider all the clarifications/amendments while preparing their bid proposals.
- b. Tenderer reserves the right not to respond to any/all queries raised or clarifications sought if, in their opinion and at their sole discretion, they consider that it would be inappropriate to do so or do not find any merit in it.

8. Amendment of Bid Documents

The amendments in any of the terms and conditions including technical specifications of this tender document will be uploaded on the website and will be binding on bidders.

9. Cost of Bid Document

The cost of Bid document is **Rs. 10,000/- (Ten Thousand only)**, the document can be purchased from the office of the Director of Higher Education, Government of Himachal Pradesh, Shimla-1, during office hours from **28-02-2014, 10:00 AM to 31-03-2014 upto 5:00 PM** and tender fee will be accepted only through demand draft issued by Nationalized Bank drawn in favour of Director of Higher Education, Himachal Pradesh, payable at Shimla. The tender document can also be downloaded from www.educationhp.org & www.himachal.nic.in. In case, the Tender document is downloaded, the bidder has to enclose a Demand Draft of tender fees for Rs. 10,000/- in favour of Director of Higher Education, Himachal Pradesh, payable at Shimla along with pre-qualification proposal.

10. Cost of Bidding

The Bidder shall bear all costs associated with the preparation and submission of its Proposal, including the cost of presentation for the purposes of clarification of the bid, if so desired by the Department of Higher Education. The Department of Higher Education will in no case be responsible or liable for all such costs, regardless of the conduct or outcome of the bid process. The tender is non-transferable. Only the party which has purchased document shall be entitled to quote.

11. EMD

- a. Bidder shall furnish an EMD of amount **Rs 30 Lacs (Thirty lac only)** in the form of a Demand draft issued by a Nationalized Bank located in India, drawn in favour of Director of Higher Education, Himachal Pradesh payable at Shimla.
- b. No other form of EMD will be accepted.
- c. EMD should be valid for at least three months.
- d. No interest shall be payable on EMD under any circumstances.
- e. The EMD of unsuccessful tenderer (s) shall be refunded to them within 30 days after the award of contract to the successful bidder. The EMD of successful bidder shall remain in the custody of tenderer till the entire supply of goods has been made by the contractor to the best of satisfaction of tenderer.
- f. Any bid not containing the EMD will be summarily rejected as non-responsive.
- g. **The EMD will be forfeited at the discretion of department of Higher Education on account of one or more of the following reasons:**
 - i. The Bidder withdraws their Bid during the period of Bid validity.
 - ii. Bidder does not respond to the requests for clarification of Bid.

- iii. Bidder fails to co-operate in the Bid evaluation process,
- iv. Bidder is found to be engaged in corrupt/fraudulent practices
- v. In case of a successful Bidder, the said Bidder fails :
 - to furnish Performance Bank Guarantee or
 - to sign the Agreement in time
 - failure to execute the contract as per terms and conditions stipulated in the tender documents.
- vi. Subsequent to the last date for receipt of bids, no modification of bids shall be allowed.
- vii. The Bidders cannot withdraw the bid in the interval between the last date for receipt of bids and the expiry of the bid validity period specified in the Bid. Such withdrawal may result in the forfeiture of its EMD.
- viii. When bidder does not execute the agreement, if any prescribed, within the specified time.
- ix. If the bid is not in conformity with the instructions mentioned in the tender document.
- x. If the bidder violates any provision of the terms and condition of the tender document.
- xi. refusal by the tenderer to accept an arithmetical error or otherwise appearing on the face of tender;

12. Bid validity

The bid shall remain valid for a period of 180 days from the date of submission of Bid. DIRECTOR OF HIGHER EDUCATION, Himachal Pradesh shall reject the proposal as being non-responsive if it is valid for a shorter period.

13. Submission of Proposals

Tender shall be submitted fully in accordance with the sequence and requirements of the Terms and Conditions. Appropriate forms prescribed with this document shall be used for filling quotations and the page number of the attached proofs should be mentioned.

1. All the proposals will have to be submitted in hard bound form with all pages numbered. It should also have an index giving page wise information of above documents. Incomplete, illegible and unsealed proposal will summarily be rejected. Telegraphic tenders will not be accepted and no correspondence will be made in this regard.
2. No bid will be considered unless and until each page of the bid document is duly signed by the authorized signatory.

3. Prices should not be indicated in the Pre-qualification Bid/Technical Bid.
4. All offers should be made in English. Conditional offers and offers qualified by vague and indefinite expressions such as "Subject to immediate acceptance", "Subject to prior sale" etc. will not be considered.
5. Submitted tender forms, with overwritten or erased or illegible rate or rates not shown in figures and words in English, will be liable for rejection. In case of discrepancy between words and figures noted against each item of the tender and between unit rates and the total amount, the amount in words will be considered final. Corrections in the tender, if unavoidable, should be made by rewriting with dated initial of the bidder after scoring out of the wrong entries. Clerical and arithmetical mistakes may result in rejection of the tender
6. Request from the bidder in respect of additions, alterations, modifications, corrections etc. of either terms and conditions or rates after opening of the tender will not be considered
7. All the columns of the bid forms shall be duly, properly and exhaustively filled in.

Procedure for Submission of Bids:

- a) Pre-Qualification Bid in one cover.
- b) Technical Bid in separate cover.
- c) Commercial Bid in another separate cover.
 - i. The pre-qualification bid should be filled in original and should be sealed in separate cover. The Pre-Qualification Bid should be super-scribed as; **PRE-QUALIFICATION BID - ENVELOPE-A and put in a cover alongwith EMD, tender fee and other required documents as per Section III Clause 5-A. The bidder should sign all pages of the PRE-QUALIFICATION BID.**
 - ii. The Technical bid should be filled in original and should be sealed in separate cover. The Technical Bid should be super-scribed as;
TECHNICAL BID - ENVELOPE-B and put in a cover comprises of the documents required as Section III Clause 5-B (Technical Bid).
 - iii. The Commercial Bid as prescribed should be filled in original in a separate cover. The Commercial BID should be super-scribed as; **COMMERCIAL BID- ENVELOPE-C. The bidder should sign all pages of the COMMERCIAL BID.** This bid must be submitted at the time of submission of Pre-qualification Bid.

- d) All these Bids should be placed in another sealed envelope and addressed to:

**DIRECTOR OF HIGHER EDUCATION
LALPANI, SHIMLA-171001, HIMACHAL PRADESH**

14. Language

The Bids and all correspondence and documents relating to the bids, shall be written in the English language.

15. Late Bids

Any bid received by the Tenderer after the time and date for receipt of bids prescribed in the tender document will be rejected and returned unopened to the Bidder.

16. Penalty and Termination due to non-fulfillment of Contract:

(a) Penalty for failure of equipment(s):

- I. No computer system/Laptop (CPU, monitor, keyboard, mouse, webcam, speakers) or LCD Projector or Interactive White Board or Integrated Computer Projector installed in the ICT Lab or smart class rooms shall be down for more than 3 working days continuously from the date of the lodging of complaint (even if computer system/ Projector/Interactive board is down during part of a calendar day, it will be counted as one calendar day). For downtime beyond 3 working days, the penalties will be imposed as under:-

No. of days	Penalty amount per school per day per equipment
1-15	@ Rs. 250/-
16-30	@ Rs. 500/-

- II. The following penalty will be imposed for the non working of the equipments such as Multifunctional Printer and UPS, if the problem is not rectified within 3 working days from the lodging of the complaint. The penalty will be counted from day one and will be calculated as under:-

No. of days	Penalty amount per school per day per equipment
1-15	@ Rs. 250/-
16-30	@ Rs. 500/-

- III. The following penalty will be imposed for the non working of the networking, if the problem is not rectified within 3 working days from the lodging of the complaint. The penalty will be counted from day one

and will be calculated as under:-

No. of days	Penalty amount per school per day
1-15	@ Rs. 250/-
16-30	@ Rs. 500/-

IV. The following penalty will be imposed if multimedia educational content remains non-functional for more than three working days from the lodging of the complaint. The penalty will be counted from day one and will be calculated as under:-

No. of days	Penalty amount per school per day
1-15	@ Rs. 250/-
16-30	@ Rs. 500/-

The Penalty on multimedia educational content will be applicable only when Projector/system/Interactive White Board is operational and multimedia educational content is non-functional.

After 30 days, if the rectification does not take place, the Principal of the concerned School, Nodal Officer (IT) alongwith Engineer of the service provider will check & verify the faulty component/equipment/hardware and concerned Principal in consultation with Nodal Officer & service engineer of the service provider will purchase the component/ equipment/hardware of same or higher specifications & same brand preferably from HP State Electronics Corp Ltd. or from open market on competitive rates. The product so purchased should be compatible with the existing hardware/software. The Principal of the concerned school will submit request to the Directorate of Higher Education for release of amount for the purchase of faulty component/equipment/hardware through concerned Dy. Director of Higher Education. The penalty imposed and amount utilized for purchase of faulty component/equipment/hardware will be deducted from the payment due towards the bidder.

If the rectification does not take place upto 30 days of the items mentioned from Sr. No. I to IV Clause 16 (a) from the lodging of the complaint and if such situation occurs in 15% or more allotted Govt. Sr. Sec. Schools, then the contract shall be terminated at the risk and cost of the bidder.

- V. Penalty @ Rs 100/- Per day will be imposed if State Project Officer remains absent without written intimation.
- VI. If the bidder fails to conduct the refreshers course of teachers as per the schedule, Penalty @ Rs 100/-per day per school will be imposed till the bidder conducts the refresher courses of teachers.
- VII. **If the bidder fails to complete all the liabilities covered under the scope of work in a school with in a stipulated period as mentioned in implementation schedule, the penalties will be imposed as under:-**

No. of days	Penalty amount per school per day
1-15	@ Rs. 250/-
16-30	@ Rs. 500/-
31-60	@ Rs. 700/-
61 onwards	@ Rs. 1000/-

All the furniture and fixtures and power point fittings need to be repaired/ replaced, as per the requirement arise during the contract period. During rectification/ repair of any equipment, the bidder will install a new equipment of same or higher configuration till the repaired equipment is received and installed. The bidder is allowed to take away the faulty equipment after replacement with a new one of same or higher configuration.

a.) Termination of contract for default: The Govt. of Himachal Pradesh without prejudice to any other remedy available for breach of contract, may terminate the contract in whole by serving 30 (thirty) days notice in writing to the bidder in the event of any one or all of the following:

- i. If the bidder fails to implement the scheme in 15% or more than 15% of the allotted schools within the given time schedule at any point of time.
- ii. If the bidder fails to provide any one or all services as per this Contract, and fails to set right the disruption in service within the 30 (thirty) days notice period or show a valid reason to Director of Higher Education for the lapse.
- iii. If the bidder has engaged in corrupt or fraudulent practices in executing the Contract.
- iv. In the event of termination of the contract for default of the bidder, Director of Hr. Education is entitled to invoke the Performance Bank Guarantee and the entire infrastructure installed in the 618 schools will become the property of the Govt.
- v. If the bidder defaults in 15% or more than 15% of the allotted schools at any time the contract will be terminated.

- vi. **In case, the total penalty amount for all schools or any number of schools on all accounts during contract period exceeds the 15% of the bid value at any point of time, then this will be counted towards default and shall lead to termination of the contract.**

“In case of termination of contract at any case, entire infrastructure like instruction material, software, hardware, furniture and site installations etc. will become the property of the Govt. of Himachal Pradesh. No compensation/payment of any kind shall be made to the bidder. Also the Performance Bank Guarantee submitted by the bidder will be invoked by the Director of Higher Education”.

- (b) **Termination for insolvency:** If the bidder becomes bankrupt or is otherwise declared insolvent, then Director of Higher Education may at any time terminate the contract by giving written notice of 30 (thirty) days to the bidder. Such termination shall not prejudice or preclude any right of the action or remedy, which has accrued or will accrue to the Director of Higher Education and vice versa.

In case of the termination of the contract for any of the reasons mentioned above, no compensation shall be due to the bidder and the entire infrastructure like instruction material, software, hardware, furniture, books and site installations etc. would become the property of the concerned School.

18. Acceptance and withdrawal:

- i. The final acceptance of the tender would be entirely vested with the Director of Higher Education who reserves the right to accept or reject any tender, without assigning any reason whatsoever. There is no obligation on the part of the Director of Higher Education to communicate in any way with the rejected bidder. After acceptance of the tender by the Director of Higher Education the bidder shall have no right to withdraw his tender or claim higher price.
- ii. Bid(s) with incomplete information are liable for rejection.
- iii. For each category of qualification criteria, the documentary evidence is to be produced, duly attested by the bidder, serially numbered and enclosed with the bids. If the documentary proof is not enclosed for any/ all criteria the bid is liable for rejection.
- iv. If any information given by the bidder is found to be false/ fictitious, the action would be initiated against the bidder as per Govt. rules.

19. Bid Forms

- i. Wherever a specific form is prescribed in the tender document, the Bidder shall use the form to provide relevant information. If the form does not provide space for any required information, space at the end of the form or additional sheets shall be used to convey the said information.
- ii. For all other cases, the Bidder shall design a form to hold the required information.
- iii. The Department of Higher Education shall not be bound by any printed conditions or provisions in the Bidder's Bid Forms/document submitted by the bidder.

20. Local Conditions

- i. Each Bidder is expected to fully get acquainted with the local conditions and factors, which would have any effect on the performance of the contract and /or the cost.
- iii. The Bidder is expected to know all conditions and factors, which may have any effect on the execution of the contract after issue of letter of Award as described in the bidding documents. The tenderer shall not entertain any request for clarification from the Bidder regarding such local conditions.
- iii. It is the Bidder's responsibility that such factors have properly been investigated and considered while submitting the bid proposals and no claim whatsoever including those for financial adjustment to the contract awarded under the bidding documents will be entertained by the Tenderer. Neither any change in the time schedule of the contract nor any financial adjustments arising thereof shall be permitted by the Tenderer on account of failure of the Bidder to know the local laws / conditions.
- iv. The Bidder is expected to visit and examine the location of Schools and its surroundings and obtain all information that may be necessary for preparing the bid at their own interest and cost.**

21. Opening of Proposal

- i. **Step 1: Envelope-A** (Prequalification Bids/s) will be opened by the Evaluation Committee, on **02-04-2014 at 2:00 PM**, in presence of bidders or their authorized representatives. Preliminary scrutiny of the pre-qualification bids will be made to determine whether they meet the eligibility criteria, whether the documents have been properly signed and whether the Bid documents are in order. The qualified Bidders in this stage would be informed of the Committee's decision either through

telephone/ fax/post /email by Directorate of Higher Education.

- ii. **Step 2: Envelope B** would be opened by the Evaluation Committee only for those bidders who qualify the pre-qualification bid.
- iii. In the event of the date specified for Bid receipt and opening being declared as a holiday, the Bids will be received/opened the following working day at the appointed times.
- iv. Any Change in the schedule on which **Envelope B** would be opened and the date and time for the conduct of demonstration /presentations will be communicated to the qualified bidders through Telephone /Fax/ Post/Telegram/E-mail.
- v. The unopened technical and commercial bids of those bidders who do not qualify pre-qualification stage, will be returned back by the department
- vi. The Bidder shall be responsible for properly super-scribing and sealing each Envelope and Bid Evaluation Committee shall not be responsible for accidental opening of Envelopes that are not properly super scribed and sealed.

22. Evaluation & Selection criteria

The Tender Evaluation Committee(s) so constituted formerly by the Department of Higher Education shall evaluate the Pre-qualification Bids, Technical Bids, Presentations and Commercial bids. The decisions of the Evaluation Committee(s) in the evaluation of the bids shall be final. No correspondence will be entertained outside the process of negotiation / discussion with the Committee(s).

- i) At the date, time and location of the bid opening as specified in the TENDER, the Evaluation Committee(s) shall open the Proposals, in the presence of Bidders' designated representatives who choose to attend. The Bidders' representatives who are present shall sign a register evidencing their attendance. The Bidders' names, and any such other details as the Evaluation Committee(s) may consider appropriate, will be announced by the Evaluation Committee(s) at the opening.
- ii) The Evaluation Committee(s) reserves the right at any time to postpone or cancel a scheduled bid opening. The bids will be opened at the address specified in TENDER.
- iii) The bidders qualified in Pre-qualification Bids would only be called for Technical Presentation.
- iv) After evaluation of technical bids, the commercial bids of only those Bidders who will qualify the technical evaluation stage, as specified in this TENDER, will be opened. The date and time of opening of the commercial bids will be announced at a later date, and the bids would be

opened in the presence of the Bidders' representatives who choose to be present.

- v) **Further, the scope of the evaluation committee also covers taking of any decision with regard to the tender document, execution/ implementation of the project including management period.**
- vi) **After the tender has been awarded to a bidder, the bidder has to submit total multimedia educational content as per the scope of work and all the submitted content will be evaluated by the evaluation committee. The suggestion made after the evaluation of this submitted content, the same has to be incorporated within the remaining total allotted days.**
- vii) **Total allotted days for submission & evaluation will be 120 days.**
- viii) Bid document shall be evaluated as per the following steps:

- a) **Preliminary Examination of Pre-qualification documents:** The Pre-qualification document will be examined to determine whether the bidder meets the eligibility criteria, completeness of the bid, whether the documents have been properly signed and whether the bids are in order. Any bid found to be non-responsive for any reason or not meeting the minimum levels of the performance or eligibility criteria specified in the various sections of this tender document will be rejected and not included for further consideration.

The Tenderer reserves the right to ask for a technical elaboration/clarification in the form of a technical presentation from the Bidder at any point of time before opening of the Commercial Proposal. The Bidder shall furnish the required information to the Department of Higher Education, as may be the case, on the date asked for, at no cost to the Tenderer. The Tenderer may at its discretion, visit the office / Operational Center of the Bidder for Services, any time before the issue of Letter of Award. No further discussion/interface will be held with the bidder whose bid has been disqualified / rejected.

b) Technical Evaluation

i. Content Evaluation

Presentation of all the submitted Multimedia Educational Contents

All bidders who meet pre-qualification criteria will be required to present all the submitted Multimedia Educational Contents in the technical bid to the Content Evaluation Committee at the time, date and venue as communicated to them.

Content Evaluation Committee will evaluate the Multimedia Educational Content in the following manner:

- any technical bid having number of topics less than or more than the minimum required number in that subject (and class) then that bid will

not be evaluated and bidder shall stand rejected at this stage only and will not be considered for further evaluation.

- will evaluate each topic subject wise, class wise and award score out of 100.
- any topic **of a class** scoring less than 50 will be categorized as **NOT ACCEPTABLE** and hence shall be **REJECTED**. The ZERO marks will be awarded in respect of that hard spot.
- all the topics will be evaluated in the manner mentioned above and each of them will be awarded score accordingly. The total score of all such acceptable topics shall be obtained.

Content Evaluation Criteria/Parameters:

Sr. No.	Criteria	Maxi. Marks	Marks obtained
1.	Clear instructions, help & support are available on how to use the content	10	
2.	Brief history & Pre-Requisite are stated	10	
3.	Desired learning outcomes are clearly stated and meets objectives	10	
4.	Coverage/scope of the contents is sufficient & easy to understand	10	
5.	Content is accurate, factual and covers minimum defined time duration	10	
6.	The content is interactive, user friendly structured & easy to access	10	
7.	Learning styles/approaches are used with assessment	10	
8.	The use of technology is appropriate and Assessment is included	10	
9.	Different learning styles/approaches are used to explain the concept	10	
10.	Language, Voice quality, Sound & Background music quality and picture is appropriate to target audience	10	
Maximum Technical score		100	

ii. Financial & Experience Evaluation:

SNo	Parameters	Score
1.	Total overall turnover of bidder in for the last three financial years in India. 300 crores to 500 crores = 4 marks 501 crores to 700 crores = 7 marks More than 700 crores = 10 marks	10
2.	The bidder should have turnover more than 150 Crores in IT/ICT/ICT related activities in India in last three financial years in India. 150-200 = 4 marks 201-250 = 7 marks More than 251 = 10 marks	10
3.	The Bidder must have trained atleast 1500 Govt. Institutions teachers in the last three years. 1500-3000 = 4 marks 3001-4000 = 7 marks More than 4000 = 10 marks	10
4.	The bidder must have implemented IT/ICT in least 500 Govt. institutions in last five financial years in India. 500-700 = 4 marks 701-900 = 7 marks More than 900 = 10 marks	10
5.	The bidder should have supplied multimedia educational content in atleast 200 Institutions in India in last three years. 200-400 = 4 marks 401-600 = 7 marks More than 600 = 10 marks	10
Total Technical Score		50

Thereafter, the final Evaluation after considering above mentioned both the criteria will be done as follows:

Sr. No.	Criteria	Maximum Marks (Weightage)	Method of allotting marks for Combined Score
1	Content Evaluation of total Hard Spots	60	The bidder with the highest marks will be awarded 60 marks and other bidders will be awarded proportionately less marks (e.g.) if the highest score is 1500, the bidder having this score will get 60 marks. A bidder having score 1000 will get $(1000/1500) \times 60 = 40$ marks.
2.	Financial & Experience Evaluation	40	The bidder with the maximum score will be awarded 40 marks and other bidders will be awarded proportionately less marks (e.g.) if highest score is 50, bidder having this will get 40 marks. Bidder having score of 30 will get $(30/50) \times 40 = 24$ marks.
Total marks		100	

All marks given will be rounded off to 2 decimal places only.

Commercial Evaluation

a) Evaluation of Commercial Bids

The commercial offers of **only those bidders will be opened who score 60 or more marks in technical evaluation. However, the evaluation committee can relax this condition if only one or two bidders are found qualified in technical bid.** The bidder will quote for the entire scope of work mentioned in the tender document. Thereafter, the evaluation committee will check quoted rate of all the qualified bidders. The bidder who quoted the lowest rate will be awarded with the work (If the rate quoted will found financially viable). The

Director of Higher Education, Himachal Pradesh reserves the right to negotiate further reduction of rates as quoted in the tender by the lowest bidder. The place, date and time for the opening of the financial bids shall be confirmed separately to only technically qualified bidders.

- i. Conditional bids shall be summarily rejected.
- ii. Evaluation committee will examine the bids to determine whether they are complete, whether any computational errors have been made, and whether

the bids are generally in order.

- iii. If there is a discrepancy between words and figures, the amount in words will prevail.
- iv. If any or all of the information asked in the tender document are not available in the Commercial Proposal the bid is liable for rejection.
- v. The Bidders are informed that discount, if any, should be merged with the quoted prices. Discount of any type, indicated separately, will not be taken into account for evaluation purposes.
- vii. The bidders who qualify for opening of the commercial bids will have to declare the OEM/brand of deliverables in a sealed envelope as per Annexure-“N” and bidder will have to provide the deliverables of same OEM/brands as declared in above mentioned annexure.

23. Source Code and IPR

The ownership of source code of all applications developed for Multimedia Educational Content shall be transferred to Government of Himachal Pradesh. Government of Himachal Pradesh shall have all rights on Software, Source Code and related documentation for its unlimited, unrestricted use within the State of Himachal Pradesh at unlimited number of locations, machines, computers, gadgets etc.

24. Language of bid & Correspondence

The Bid will be prepared by the Bidder in English language only. All the documents relating to the Bid (including brochures) supplied by the bidder should also be in English, and the correspondence between the bidder & DIRECTOR OF HIGHER EDUCATION, Himachal Pradesh will be in English language only. The correspondence by Fax/E-mail must be subsequently confirmed by a duly signed formal copy.

25. Bid currencies

Prices shall be quoted in INDIAN RUPEES, inclusive of all prevailing taxes, fees and other charges including service tax.

26. Deciding Award of Contract

- i. The Evaluation committee will select that Bidder(s) as the "BOOT Operator", who has quoted the lowest amount for 1450 Government schools + 5 Smart schools + 70 Government Schools and maintenance thereof.
- ii. In case of a situation where lowest bid quoted by the bidders are equal then such bidders may be offered an opportunity to quote a revised quote

in sealed envelopes. In such a situation, the bidder offering the lowest revised quote will be declared as successful bidder.

- iii. In case there is a single bid, the same may be accepted by the tenderer and will be referred to the Govt. for further decision.
- iv. Negotiations, if any, will be held with the Bidder in the office of the tenderer.
- v. The evaluation committee's decision would be final and binding to the Bidders.
- vi. Prior to the expiry of the period of Bid validity, the successful Bidder will be notified by the tenderer, that the Bid has been accepted.
- vii. Letter of Award will be issued to the lowest bidder, if the bid found financially viable.**
- viii. The successful bidder will have to sign an agreement with Director of Higher Education within 15 days of the issuance of letter of the award and all the expenses involved for the preparation of agreement has to be borne by the successful bidder.

27. Confidentiality

As used herein, the term "Confidential Information" means any information, including information created by or for the other party, whether written or oral, which relates to internal controls, computer or data processing programs, algorithms, electronic data processing applications, routines, subroutines, techniques or systems, or information concerning the business or financial affairs and methods of operation or proposed methods of operation, accounts, transactions, proposed transactions or security procedures of either party or any of its affiliates, or any client of either party, except such information which is in the public domain at the time of its disclosure or thereafter enters the public domain other than as a result of a breach of duty on the part of the party receiving such information. It is the express intent of the parties that all the business process and methods used by the Bidder in rendering the services hereunder are the Confidential Information of the Bidder.

The Bidder shall keep confidential any information related to this tender with the same degree of care as it would treat its own confidential information. The

Bidders shall note that the confidential information will be used only for the purposes of this tender and shall not be disclosed to any third party for any reason whatsoever.

At all times during the performance of the Services, the Bidder shall abide by all applicable security rules, policies, standards, guidelines and procedures. The Bidder should note that before any of its employees or assignees is given access to the Confidential Information, each such employee and assignees shall agree to be bound by the term of this tender and such rules, policies,

standards, guidelines and procedures by its employees or agents.

The Bidder should not disclose to any other party and keep confidential the terms and conditions of this Contract agreement, any amendment thereof, and any Attachment or Annexure thereof. The obligations of confidentiality under this section shall survive rejection of the contract.

Any information pertaining to the Govt. of Himachal Pradesh or any other agency involved in the project, matters concerning Govt. of Himachal Pradesh that comes to the knowledge of the vendor in connection with this contract, will be deemed to be confidential and the bidder will be fully responsible, for the same being kept confidential and held in trust, as also for all consequences of its concerned personnel failing to observe the same. The vender shall ensure due secrecy of information and data not intended for public distribution.

28. Publicity

Any publicity by the bidder in which the name of ICT Project in Himachal Pradesh is to be used, should be done only with the explicit written permission from the Department of Higher Education.

29. Insurance

The equipments/deliverables and services supplied under the contract shall be fully insured by the bidder against theft, loss or damage by fire, flood/cloudburst/natural calamity or otherwise, incidental to manufacture or acquisition, transportation, storage, delivery and installation. The period of insurance shall be for the entire contract period. For insurance claims, the respective school authorizes will lodge FIR and provide NTR report. The Bidder will provide the replacement of equipment/component/hardware within a period of one week.

30. Arbitration

All disputes, differences, claims and demands arising under the contract shall be referred to the Principal Secretary (Education), to the Govt. of Himachal Pradesh, for final decision and the same shall be binding on all parties. Principal Secretary (Education), to the Govt. of Himachal Pradesh and the selected Service Provider shall make every effort to resolve amicably through direct negotiation, any disagreement or dispute arising between them under or in connection with the work order. If any dispute arises between parties on aspects not covered by this agreement, or the construction or operation thereof, or the rights, duties or liabilities under these except as to any matter the decision of which is specially provided for by the general conditions, such disputes shall be referred to Sole Arbitrator, Principal Secretary (Education), to the Govt. of Himachal Pradesh. Such arbitration shall be governed in all respects by the provision of the Indian Arbitration and Conciliation Act, 1996 and the rules there under and any statutory modification or reenactment thereof the arbitration proceeding shall be held in Shimla.

31. Legal jurisdiction

All legal disputes are subject to the jurisdiction of Shimla courts only.

32. Payment structure:

The 30% payment of contract value shall be made by the Directorate of Higher Education, after successful delivery and installation of hardware, software and connected accessories, within one month from the date of drawl from Govt. Treasury at the rates quoted or agreed as per the agreement. The remaining 70% payment shall be made in form of equal Quarterly installments (once every three months) over the contract period, by the Directorate of Higher Education within one month from the date of drawl from Govt. Treasury at the rates quoted or agreed as per the agreement. If there happens to be a holiday on that day then payment will be made on the next day. The payment period will be for the contract period which would start from the date of commencement of the project

The payment period will be for the contract period which would start from the date of successful delivery and installation of hardware, software and connected accessories, commencement of the project.

- I. The payments for each school site shall include the procurement, implementation, operation and maintenance of equipments along with providing the specified services for the entire service period as specified in the schedule of requirement section.
- II. The bidder shall make a payment request in the month of March of every financial year separately to Director of Higher Education. All Dy. Directors of Higher Education will submit details of amount due and penalty, if any to the Directorate and accordingly penalty amount will be withheld and rest amount will be released to the service provider.
- III. No payments shall accrue until the performance bank guarantee has been furnished.
- IV. The payments shall be made after deducting all penalties imposed on the bidder.
- V. Any extra charges required for the preparation of demand draft will be deducted from the due payment towards the bidder.

Section IV - Special Conditions of Contract

32. Site Preparation and Site Survey

As per implementation plan, Department of Higher Education shall arrange the necessary minimum constructed rooms/ permanent construction for locating ICT Lab and smart class rooms for operation of the ICT Project. The space cannot be used for any purpose other than for delivering the services as contracted under the Agreement. The Department of Higher Education shall arrange for necessary clearances, which shall enable the Bidder to undertake electrical wiring, earthing, dust free room, installation of furniture, installation of UPS equipment, network cable laying etc., at the respective school sites.

33. Performance Bank Guarantee for Operations

Performance Bank Guarantee - ICT in Government Senior Secondary Schools

Bidder shall furnish Performance Bank Guarantee to Department of Higher Education for an amount equal to 5% of the total bid value quoted by bidder in commercial offer at the time of signing of agreement. The Performance Bank Guarantee shall be valid upto next 6 month of expiry of contract period. The Department of Higher Education may forfeit the Performance Bank Guarantee for any failure on part of bidder to complete its obligations under the agreement. The Performance Bank Guarantee shall be denominated in Indian Rupees and shall be absolutely, irrevocably and unconditional guarantee in the form of a Performance Bank Guarantee issued by a Nationalized Bank and payable at Shimla. In the event of any amendments to Agreement, the bidder shall within 15 days of receipt of such amendment furnish the amendment to the Performance Bank Guarantee as required.

34. Force Majeure

Neither party shall be responsible to the other for any delay or failure in performance of its obligations due to any occurrence commonly known as Force Majeure which is beyond the control of any of the parties, including, but without limited to, fire, flood, explosion, acts of God, public disorder, riots, embargoes, or strikes, acts of military authority, epidemics, strikes, lockouts, insurrections, civil commotion, war, enemy actions. If a Force Majeure arises, the Bidder shall promptly notify tenderer in writing of such condition and the cause thereof. Unless otherwise directed by Tenderer, the successful bidder shall continue to perform his obligations under the contract as far as is reasonably practical, and shall seek all reasonable alternative means for performance not prevented by the Force Majeure event.

The successful bidder shall be excused from performance of his obligations in whole or part as long as such causes, circumstances or events shall continue to prevent or delay such performance.

35. Representations and warranties by the Bidder

- i. There is no pending or threatened actions, suits or proceedings affecting the Bidder or its affiliates or any of their respective assets before a court, governmental agency, commission or arbitrator or administrative tribunal which affects the Bidder's ability to perform its obligations under the Agreement; and neither Bidder nor any of its affiliates have immunity from the jurisdiction of a court or from legal process (whether through service of notice, attachment prior to judgment, attachment in aid of execution or otherwise);
- ii. The Bidder confirms that all representations and warranties of the Bidder set forth in the bid are true, complete and correct in all respects;
- iii. No information given by the Bidder in relation to the Agreement, project documents or any document comprising security contains any material misstatement of fact or omits to state as fact which would be materially adverse to the enforcement of the rights and remedies of Department of Higher Education or which would be necessary to make any statement, representation or warranty contained herein or therein true and correct;
- iv. All equipment including material to be installed by the Bidder in the ICT Project shall be branded & new and the product should not be de-supported or declared end of life within next 5 years. **A certificate to that effect should be furnished from OEM.** All equipment shall conform to the codes, standards and regulations applicable and benefit from the usual manufacturer's guarantee

Section V Annexure

Annexure A: Bid Letter

Date: dd/mm/yyyy

To,

The Director of Higher Education
Himachal Pradesh, Lalpani, Shimla-171001 (HP)

Subject: For of the supply and installation of the Multimedia Educational Content, teacher training/ refresher courses, monitoring, Interactive White Board, Projector, Integrated Computer Projector, Computer Hardware, manpower, software, and other allied accessories (i.e. webcam, multifunctional printers, UPS, etc.), site preparation (i.e. vinyl flooring, furniture and fixtures, electrical fittings, power back up facilities, LAN, etc.) Maintenance thereof.

Sir,

We, the undersigned Bidders, having read and examined in detail the specifications and tender document in respect **supply and installation of the Multimedia Educational Content, teacher training/ refresher courses, monitoring, Interactive White Board, Projector, Integrated Computer Projector, Computer Hardware, manpower, software, and other allied accessories (i.e. webcam, multifunctional printers, UPS, etc.), site preparation (i.e. vinyl flooring, furniture and fixtures, electrical fittings, power back up facilities, LAN, etc.) Maintenance thereof.**

Price and Validity

1. All the prices mentioned in our commercial offer are in accordance with the terms as specified in tender document. All the prices and other terms and conditions of this proposal are valid for a period of 180 days from the last date of submission of bids.
2. We do hereby confirm that our bid prices include all taxes and cess including Income Tax.
3. We have studied the Clauses relating to Indian Income Tax and hereby declare that if any Income Tax, Surcharge on Income Tax and any other Tax is altered under the law, we shall pay the same.

Earnest Money

We have enclosed the required earnest money in the form of Bank draft in pre-qualification bid/pre bid conference.

Bid Pricing

We further declare that the RATES stated in our proposal are in accordance with your terms & conditions in the bidding document.

Qualifying Data

We confirm having submitted in qualifying data as required by you in your

tender document. In case you require any further information/ documentary proof in this regard before evaluation of our bid, we agree to furnish the same in time to your satisfaction.

We hereby declare that our proposal is made in good faith, without collusion or fraud and the information contained in the proposal is true and correct to the best of our knowledge & belief.

We here by declare to accept and abide by all term & conditions mentioned in the tender document.

Bid submitted by us is properly sealed and prepared so as to prevent any subsequent alteration and replacement.

We understand that you are not bound to accept the lowest or any bid you may receive.

Thanking you,

Yours faithfully,

(Signature)

Date:

Place:

Business Address:

Name:

Designation:

Seal

Annexure B: Bidder profile

Sr. No Details

1. Name of the Firm/organization
2. Registered office
address Telephone
Number
Fax
Number e-
mail
3. Correspondence/ contact address
4. Details of Contact person
(Name, designation, address etc.) Telephone
Number
Fax
Number e-
mail
5. Is the firm a registered company? If yes,
submit Documentary proof. Year and Place
of the establishment of the Company.
6. Former name of the company, if any. And
how many years has your organization been
in business under your present name?
7.
 - Is the firm Government/ Public
Sector
Undertaking propriety firm partnership
firm (if yes, give partnership deed)
 - limited company or limited corporation
member of a group of companies (if yes,
give name and address, and description
of other companies)
 - Subsidiary of a large corporation (if yes
give the name and address of the parent
organization) If the company is
subsidiary, state what involvement if any,
will the parent company have in the
project.
8. Is the firm registered with sales tax
department? If yes, submit valid sales tax
registration certificate.
9. Is the firm registered for service tax with
Central Excise Department (Service Tax
Cell)? If yes, Submit valid service tax
registration certificate.
10. Is the firm registered under Labour Laws
Contract Act? If yes, submit valid
registration certificate.

12. Total number of employees
13. Number of offices / Project Locations

14. Do you have a local representation /office in Himachal Pradesh? If so, please give the address and the details of staff, infrastructure etc in the office and no. of years of operation of the local office
15. Is your organization has ISO/or any other certification? If so, attach copies of the certificates. State details, if certified by bodies, other than that stated.
16. List the major clients with whom your organization has been/ is currently associated.
17. The bidder shall disclose details pertaining to all contingent liabilities, claims, disputes, matters in appeal & in court and any pending litigation against the bidder or any member of the Consortium. If nil, an undertaking from the bidder mentioning the same.
18. Have you ever been denied tendering facilities by any Government/ Department/ Public sector Undertaking? (Give details)

Signature & Seal of the Bidder:

Annexure C: Financial Information Summary

(to be certified by CA)

S.NO		(Rs. Crores)			
		2010-11	2011-12	2012-13	Total
1	Total turnover				
2	Annual Turn Over in IT/ICT/ ICT related activities				
3	Profitability (Profit after tax)				

Signature

Seal of Chartered Accountant

Note: Please enclose audited financial statements for the respective years

Annexure D: Summary of Teachers Training/Institutions covered a)**Total number of Teachers trained in last three years**

Year	No. of Teachers Trained	Name of the State Govt./ organization/Educational Institutions
2010-11		
2011-12		
2012-13		
Total		

b) Number of Institutions covered under IT/ICT in India

Year	No. of schools	Name of the State Govt./Educational Institutions
2010-11		
2011-12		
2012-13		
Total		

Annexure -E: Supply of Multimedia educational content to Institutions

Year	No. of multimedia educational content supplied	Name of the Institution
2010-11		
2011-12		
2012-13		
Total		

Signature & Seal of the Bidder:

Annexure F: Commercial Bid - Payment for ICT in 1450 Govt. Schools + 5 smart schools + 70 Govt. Schools in Department of Higher Education

Date: / /

To

Director of Higher Education
Lalpani, Shimla-1 (Himachal Pradesh)

Re: Commercial Bid

Having examined the Bid Document, we the undersigned, offer to quote the following rates per month per school towards entire scope of work mentioned under Section –II schedule of requirements.

SCOPE OF WORK

Part-A: 1450 Govt. Schools + 5 Smart Schools and 70 Govt. Schools Rate for per month per School: (In figure)

.....
(In Words)

Rs......

Rate per 10 minutes for additional/new topics=

Note: Above prices should include all taxes applicable, transport, insurance, installation etc. as applicable at schools site. Conditional bids will be summarily rejected.

CONDITIONS:

- a) We undertake, if our Bid is accepted, we shall establish and operate all services in 1450 Govt. Schools, 5 smart schools and 70 newly upgraded Govt. Schools awarded to us in accordance with the terms and conditions in tender document.
- b) If our Bid is accepted, we will furnish Performance Bank Guarantee to the Department of Higher Education for an amount equal to 5% of the bid value issued by a Nationalized Bank and payable at SHIMLA at the time of signing of agreement.
- c) Until a formal contract is prepared and executed, this bid, together with your written acceptance thereof and your notification of award shall constitute a binding contract between us.

- d) We understand that in competing for and if the award is made to us, in executing the above contract we will strictly observe the laws against fraud and corruption in force in India namely "Prevention of corruption act 1988".
- e) We understand that you are not bound to accept a lowest offer that you may receive.

BID VALIDITY

The Bid is valid for a period of 180 days from the date of opening of

Bid. Place:

Date:

Signature & Seal of the Bidder:

“Annexure-H”

List of training centres with available hardware

Sr.No	District wise	Sr. No.	Name of the College	Computer	Projector
1	Solan	1	SCERT Solan	20	1
		2	Govt. College Arki	10	1
		3	Govt. College, Nalagarh	14	1
2	Sirmour	4	Govt. C ollege Nahan	17	1
		5	Govt. College, Paunta Sahib	12	1
3	Shimla	6	Govt. College, Chaura-Maidan	14	1
		7	Govt. College, Seema	0	0
		8	Govt. College, Sarswatinagar	10	1
		9	Govt. College, Rampur-Bushhar	27	1
4	Kinnour	10	Govt. College, Reckong-Peoo/ MMC at GSSS Reckong Peo	4	1
5	Bilaspur	11	Govt. College, Ghumarwin	17	1
		12	Govt. College, Bilaspur	10	1
6	Mandi	13	Govt. College, Mandi	75	1
		14	Govt. College, Sarkaghat	19	1
		15	Govt. College, Karsog	10	1
7	Chamba	16	Govt. College, Chamba	15	1
		17	Govt. College, Chowari	25	1
8	Una	18	Govt. College, Una	25	1
		19	Govt. College, Dharamsala	44	1
9	Kangra	20	Govt. College, Nurpur	10	1
		21	Govt. College, Palampur	37	1
		22	Govt. College, Hamirpur	23	1
10	Hamirpur	23	Govt. College, Nadaun	9	1
		24	Govt. College, Sujampur	20	1
		25	Govt. College, Bhoranj	8	1
		26	Govt. College, Kullu	38	1
11	Kullu	27	Govt. College, Banjar	9	1
		28	Govt. College, Anni at Haripur	5	1
		29	MMC at GSSS Keylong	10	1 To be arranged from GDC Lambathach

Wooden Cabinet for keeping CPU, Keyboard and mouse in Smart Classroom

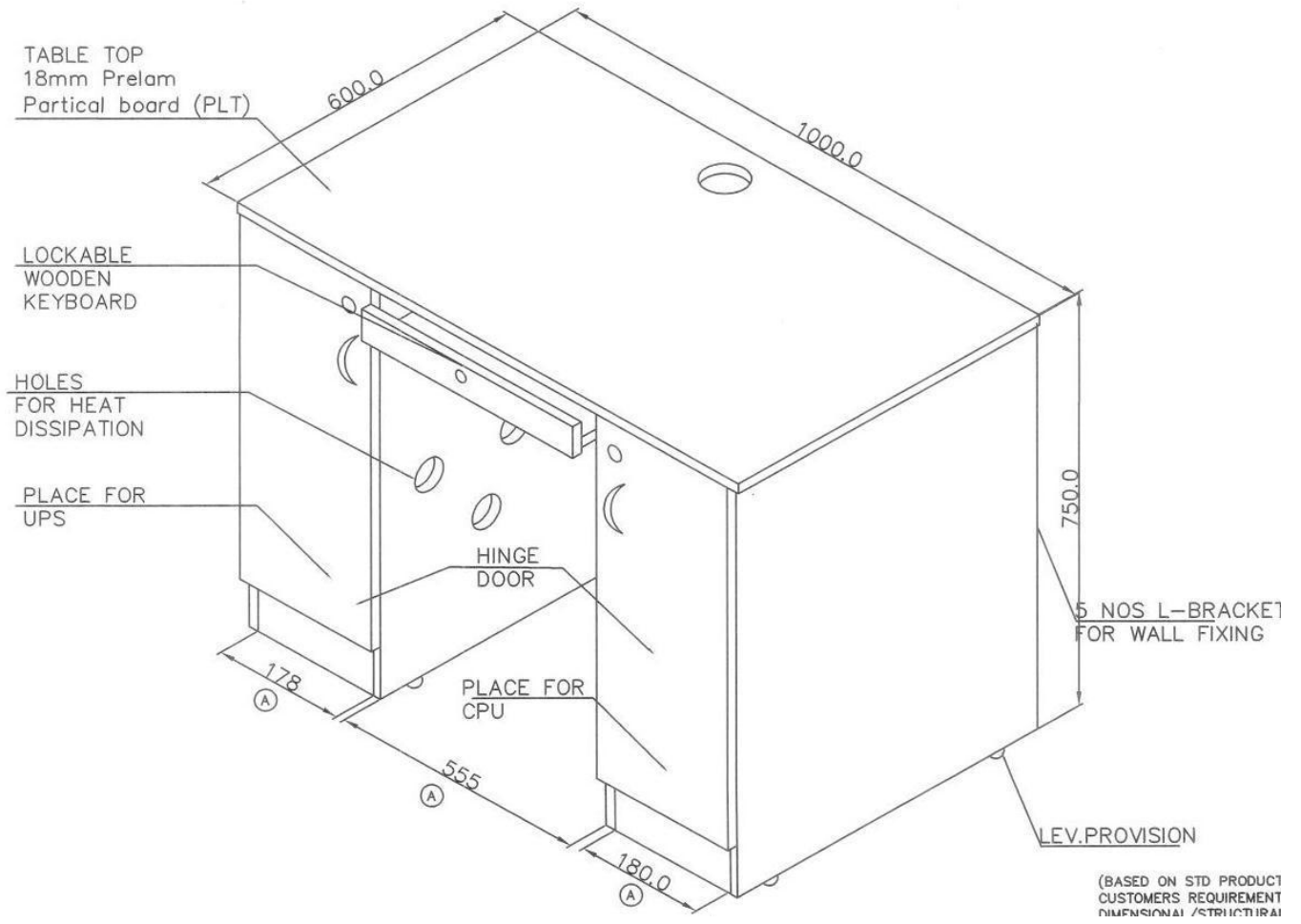

List of Topics to be submitted with the Technial Bid.

Class: 10th

Subject: Mathematics

SURFACE AREAS AND VOLUMES

1. Problems on finding surface areas and volumes of combinations of any two of the following cubes, cuboids, spheres and hemispheres.

Class: 10th

Subject: English

Grammar

1. A variety of short questions involving the use of particular structures within a context. Text types used include cloze, gap-filling, sentences completion, sentence-reordering, dialogue-completion and sentence transformation (including combining sentences). The Grammar syllabus will include the following areas for teaching:
 1. Use of non- finites.

Class: 10th

Subject: Science

Theme: Natural Phenomena

1. Convergence and divergence of light. Images formed by a concave mirror; related concepts; centre of curvature; principal axis. Optic centre, focus, focal length.

Class: 10th

Subject: Social Science

Water resources:

1. Sources, distribution, utilization, multipurpose projects, water scarcity, need for conservation and management, rainwater harvesting

Class: 10th

Subject: Hindi

जार्ज पंचम की नाक

Class: +1

Subject: History

Paths to Modernization

- Focus on East Asia. Late 19th and 20th century.
- (a) Militarization and Economic growth in Japan.
 - (b) China and the Communist alternative.

Class: +2

Subject: Accountancy

Unit 3 : Reconstitution of Partnership

Changes in Profit Sharing Ratio among the existing partners-Sacrificing Ratio and Gaining Ratio.

- a. Accounting for Revaluation of Assets and Liabilities and distribution of reserves and Accumulated Profits.

Class: +2

Subject: Business Studies

Part-B : Business Finance and Marketing

Unit 9 : Financial Management

Meaning, role, objectives of financial management

- a. Financial planning - meaning and importance
- b. Capital Structure - meaning and factors

Class: +2

Subject: Mathematics

Three - Dimensional Geometry

Direction cosines/ratios of a line joining two points. Cartesian and vector equation of a line, coplanar and skew lines, shortest distance between two lines.

Class: +2

Subject: Physics

Unit VIII: Atomic & Nuclei

Alpha-particle scattering experiment, Rutherford's model of atom; Bohr model, energy levels, hydrogen spectrum. Composition and size of nucleus

Class: +2

Subject: Chemistry

Unit IX : Coordination Compounds

Coordination Compounds - introduction, ligands and coordination number, colour, magnetic properties and shapes, IUPAC nomenclature of mononuclear coordination compounds.

Class: +2

Subject: Geography

Unit 10 : Transport, Communication and International Trade

Transport and communication - roads, railways, waterways and airways; oil and gas pipelines; national electric grids;

Class: +1

Subject: Biology

CELL: Structure and Function

Cell: Cell wall, cell membrane and cell organelles' (plastids, mitochondria, endoplasmic reticulum)

Class: +1 Subject: English Grammar

Different grammatical structures in meaningful context will be tested. Item types will include gap-filling, sentence - reordering dialogue-completion and sentence-transformation. The grammar syllabus will include the following areas:

Determiners, Tenses, Clauses, Modals and Error Correction

Class: +1

Subject: Economics

Human Capital Formation: How people become resource; Role of human capital in economic development, Growth of Education Sector in India.

Annexure -N

OEM/Brand wise details of deliverables

S.No.	Item /deliverable name	OEM	Brand/ Model No.

List of 1450 Govt. Schools, 5 Smart Schools and 70 Newly upgraded Government Schools

615 Govt. Sr. Secondary Schools

Sr.	UDISE CODE	Name of the School	District	PIN CODE
1	2010100102	GSSS MAIL	CHAMBA	176301
2	2010100702	GSSS SHERPUR	CHAMBA	176306
3	2010100902	GSSS NAINIKHAD	CHAMBA	176301
4	2010102102	GSSS BAGDHAR	CHAMBA	176303
5	2010201802	GSSS MANDHA	CHAMBA	176324
6	2010202802	GSSS POOLIN	CHAMBA	176315
7	2010300802	GSSS ZADERA	CHAMBA	176314
8	2010305502	GSSS KHAJJAR	CHAMBA	176314
9	2010306102	GSSS KOHLARI	CHAMBA	176310
10	2010306702	GSSS BAROR	CHAMBA	176314
11	2010401302	GSSS RAIPUR	CHAMBA	176302
12	2010402902	GSSS PARCHHOR	CHAMBA	176302
13	2010405702	GSSS HOBAR	CHAMBA	176313
14	2010407102	GSSS SAHLA	CHAMBA	176302
15	2010503302	GSSS RANUH KOTHI	CHAMBA	176324
16	2010504202	GSSS GAROLA	CHAMBA	176309
17	2010504402	GSSS CHANHOUTA	CHAMBA	176309
18	2010600702	GSSS KARIAN	CHAMBA	176318
19	2010604702	GSSS KIRI	CHAMBA	176314
20	2010606502	GSSS LUDDU	CHAMBA	176318
21	2010608501	GSSS RANDOH	CHAMBA	176314
22	2010701103	GSSS KUTHER	CHAMBA	176319
23	2010702102	GSSS PUKHRI	CHAMBA	176319
24	2010705102	GSSS CHANDI	CHAMBA	176312
25	2010706301	GSSS SAROL	CHAMBA	176310
26	2010802403	GSSS GUWAN	CHAMBA	176311
27	2010802602	GSSS BAKANI	CHAMBA	176311
28	2010902402	GSSS DHARWAS	CHAMBA	176323
29	2010904002	GSSS SECHU NALA	CHAMBA	176323
30	2010904802	GSSS PURTHI	CHAMBA	176323
31	2011000502	GSSS MANJEER	CHAMBA	176312
32	2011000602	GSSS BHANDAL	CHAMBA	176320
33	2011001402	GSSS KIHAR	CHAMBA	176320
34	2011004701	GSSS HIMGIRI	CHAMBA	176321
35	2011005902	GSSS DIUR	CHAMBA	176320

36	2011100102	GSSS HATLI	CHAMBA	176223
37	2011100902	GSSS GOLA	CHAMBA	176207
38	2011102302	GSSS SAMOTE	CHAMBA	176207
39	2011104202	GSSS THULEL	CHAMBA	176207
40	2011105102	GSSS KHARGAT	CHAMBA	176207
41	2011202302	GSSS BAGGI	CHAMBA	176325
42	2011202402	GSSS SIMANI	CHAMBA	176308
43	2011204502	GSSS BHALEI	CHAMBA	176308
44	2011207802	GSSS MALAL	CHAMBA	176312
45	2011208401	GSSS TIKROO	CHAMBA	176320
46	2011304202	GSSS JHAJJA KOTHI	CHAMBA	176316
47	2011304303	GSSS BAIRAGARH	CHAMBA	176316
48	2011400102	GSSS GEHRA	CHAMBA	176324
49	2011402702	GSSS BATOT	CHAMBA	176311
50	2011405502	GSSS LYLH	CHAMBA	176311
51	2011500302	GSSS DUGLI	CHAMBA	176319
52	2011500602	GSSS CHANJU	CHAMBA	176321
53	2011502002	GSSS LOHTIKRI	CHAMBA	176321
54	2011502502	GSSS KALHEL	CHAMBA	176319
55	2011503802	GSSS JASSAURGARH	CHAMBA	176321
56	2020102502	GSSS GADIARA	KANGRA	176125
57	2020102902	GSSS GHIRTHOLI	KANGRA	176125
58	2020103302	GSSS GOWAL TIKKER	KANGRA	176061
59	2020105302	GSSS KOTHI KOHAR	KANGRA	176122
60	2020105902	GSSS KUNSAL	KANGRA	176125
61	2020106401	GSSS LANOUD	KANGRA	176115
62	2020109202	GSSS SAKRI	KANGRA	176125
63	2020111004	GSSS UTTRALA	KANGRA	176115
64	2020200201	GSSS ATAYALA DAI	KANGRA	176083
65	2020202602	GSSS DHATTI	KANGRA	176093
66	2020204902	GSSS KIARBAN	KANGRA	176084
67	2020209701	GSSS SANHOON	KANGRA	176093
68	2020401802	GSSS BATHRA	KANGRA	177112
69	2020406602	GSSS LAG BALIANA	KANGRA	177107
70	2020407701	GSSS NALSUHA	KANGRA	177104
71	2020409502	GSSS SEUL	KANGRA	177112
72	2020410103	GSSS SUNHET SWARA	KANGRA	177101
73	2020501301	GSSS MAHADEV	KANGRA	176030
74	2020505702	GSSS KHERIAN	KANGRA	176028
75	2020506902	GSSS PAISA	KANGRA	177101
76	2020509102	GSSS THILL	KANGRA	176055
77	2020509901	GSSS NAHLIAN	KANGRA	176030

78	2020600602	GSSS BARWALA	KANGRA	176001
79	2020603103	GSSS GHANIARA	KANGRA	176057
80	2020606102	GSSS PASSU	KANGRA	176057
81	2020606702	GHS SAKOH	KANGRA	176213
82	2020702902	GSSS DIANA	KANGRA	176058
83	2020703501	GSSS HATLI	KANGRA	176058
84	2020703702	GSSS HOURI DEVI	KANGRA	176022
85	2020705002	GSSS KHATJAR	KANGRA	176025
86	2020707102	GSSS NANGAL	KANGRA	176058
87	2020710001	GSSS MAKROLI	KANGRA	176022
88	2020805301	GSSS MALAHRI	KANGRA	176401
89	2020904701	GSSS PALOURA	KANGRA	176023
90	2020905202	GSSS SIDHPUR GHAR	KANGRA	176021
91	2021001602	GSSS BOHAR KWALU	KANGRA	176001
92	2021002702	GSSS GAHLIAN	KANGRA	176029
93	2021003102	GSSS GHEEN	KANGRA	176029
94	2021004603	GSSS OLD KANGRA	KANGRA	176002
95	2021006202	GSSS NANDROOL	KANGRA	176001
96	2021006602	GSSS RAJAL	KANGRA	176001
97	2021006701	GSSS RAJIANA BANDH	KANGRA	176029
98	2021009603	GSSS ZAMANABAD	KANGRA	176001
99	2021100403	GSSS BACHHWAI	KANGRA	176107
100	2021102102	GSSS SIHORBALA	KANGRA	176098
101	2021104202	GSSS DHUPKIAR	KANGRA	176096
102	2021106902	GSSS KAUNA	KANGRA	176107
103	2021107902	GSSS LAHAT	KANGRA	176086
104	2021108102	GSSS LAHRU	KANGRA	176098
105	2021109502	GSSS PAPLAH	KANGRA	176073
106	2021200102	GSSS AERLA	KANGRA	176054
107	2021203701	GSSS KANDI DHOLRAN	KANGRA	176054
108	2021206603	GSSS SADDUN BADGRAN	KANGRA	176037
109	2021208104	GSSS UPPER KOTHI	KANGRA	176047
110	2021301302	GSSS CHANDUA	KANGRA	176026
111	2021303702	GSSS MASROOR	KANGRA	176026
112	2021304302	GSSS SAKRI	KANGRA	176027
113	2021400303	GSSS AUNDH	KANGRA	176202
114	2021402302	GSSS BHALI	KANGRA	176206
115	2021406202	GSSS JASSUR	KANGRA	176201
116	2021407003	GSSS KANDWAL	KANGRA	176201
117	2021407302	GSSS KHANNI	KANGRA	176201
118	2021413202	GSSS TILOKPUR	KANGRA	176225
119	2021501802	GSSS DARANG	KANGRA	176060

120	2021504005	GSSS KHALET	KANGRA	176102
121	2021507302	GSSS DADH	KANGRA	176052
122	2021507402	GSSS BALLAH	KANGRA	176064
123	2021601703	GSSS BUNDLA	KANGRA	176061
124	2021608802	GSSS RAKKAR	KANGRA	176063
125	2021609502	GSSS TATEHAL	KANGRA	176103
126	2021610201	GSSS BHOURA	KANGRA	176087
127	2021702302	GSSS BOH	KANGRA	176206
128	2021704203	GSSS DURGELLA	KANGRA	176206
129	2021705702	GSSS KANOL	KANGRA	176206
130	2021707702	GSSS MANAI	KANGRA	176210
131	2021709002	GSSS PARGOUR	KANGRA	176210
132	2021709702	GSSS RAJOL	KANGRA	176208
133	2021710802	GSSS SEHWAN	KANGRA	176206
134	2021712401	GSSS GHAROH	KANGRA	176215
135	2021800303	GSSS BARANDA	KANGRA	176201
136	2021805902	GSSS MINJGRAN	KANGRA	176200
137	2021807502	GSSS SUKHAR	KANGRA	176051
138	2021900302	GSSS KUTIARA	KANGRA	176036
139	2021907402	GSSS PIHRI	KANGRA	176107
140	2021908202	GSSS SALETI	KANGRA	177043
141	2021908602	GSSS SEHORPAIN	KANGRA	176031
142	2021909401	GSSS TIHRI	KANGRA	176032
143	2030101702	GSSS-SISSU	LAHUL & SPITI	175140
144	2030104102	GSSS-KOLONG	LAHUL & SPITI	175132
145	2030104903	GSSS-DARCHA	LAHUL & SPITI	175132
146	2030200602	GSSS- MALANG	LAHUL & SPITI	175132
147	2030201402	GSSS- LOTE	LAHUL & SPITI	175133
148	2030201902	GSSS-SHANSHA	LAHUL & SPITI	175139
149	2030300102	GSSS-THIROT	LAHUL & SPITI	175139
150	2030300404	GSSS- TRILOKNATH	LAHUL & SPITI	175142
151	2030300904	GSSS-MADGRAN	LAHUL & SPITI	175142
152	2030301704	GSSS- TINGRET	LAHUL & SPITI	175142
153	2030302105	GSSS SHAKOLI	LAHUL & SPITI	175142
154	2030302304	GSSS- TINDI	LAHUL & SPITI	175142
155	2030401403	GSSS LOSSAR	LAHUL & SPITI	172114
156	2030401502	GSSS RANGRIK	LAHUL & SPITI	172114
157	2030401903	GSSS SAGNAM	LAHUL & SPITI	172117
158	2030402003	GSSS TABO	LAHUL & SPITI	172113
159	2040101704	GSSS JAGATSUKH	KULLU	175143
160	2040102106	GSSS PANGAN	KULLU	175129
161	2040200505	GSSS KAIS	KULLU	175138

162	2040201206	GSSS PEEJ	KULLU	175101
163	2040201905	GSSS SARI(BHEKHLI)	KULLU	175101
164	2040202504	GSSS BHALYANI	KULLU	175102
165	2040202707	GSSS SHALLANG	KULLU	175102
166	2040300804	GSSS MOHAL	KULLU	175126
167	2040302402	GSSS DIYAR	KULLU	175141
168	2040303203	GSSS CHHAMAHAN	KULLU	175125
169	2040304004	GSSS PINI	KULLU	175105
170	2040304108	GSSS BARSHAINY	KULLU	175105
171	2040304208	GSSS MANIKARAN	KULLU	175105
172	2040400204	GSSS MOHANI	KULLU	175123
173	2040400608	GSSS JIBHI	KULLU	175123
174	2040401803	G.S.S.S.GUSHANI	KULLU	175123
175	2040402006	GSSS CHANON	KULLU	175123
176	2040402203	GSSS THATIBIR	KULLU	175106
177	2040403804	GSSS SHANSHER	KULLU	175134
178	2040500609	GSSS LUHRI	KULLU	172001
179	2040501204	GSSS CHOWAI	KULLU	172032
180	2040501405	GSSS BUCHHER	KULLU	172032
181	2040501603	GSSS KHANAG	KULLU	172026
182	2040501704	GSSS KHUN	KULLU	172026
183	2040502007	GSSS KOTHI	KULLU	172026
184	2040502704	GSSS LAGOUTI	KULLU	172026
185	2040600106	GSSS SAMEJ	KULLU	172201
186	2040600305	GSSS KHARGA	KULLU	172201
187	2040601205	GSSS JAON	KULLU	172002
188	2040601403	GSSS BAGIPUL	KULLU	172002
189	2040602305	GSSS SARAHAR	KULLU	172033
190	2050104902	GSSS NAGWAIN	MANDI	175121
191	2050105302	GSSS SERICHARTIGARH	MANDI	175125
192	2050105702	GSSS THALOUT	MANDI	175121
193	2050111001	GSSS SAROA	MANDI	175124
194	2050202906	GSSS NAU-PNAU	MANDI	175121
195	2050207602	GSSS DEORI	MANDI	175124
196	2050213301	GSSS KOT SNORE	MANDI	175121
197	2050213801	GSSS BALU	MANDI	175121
198	2050306101	GSSS SALWANA	MANDI	175030
199	2050310703	GSSS DHAWAL	MANDI	174403
200	2050400601	GSSS PHANGWAS	MANDI	175031
201	2050402502	GSSS BALAG	MANDI	175038
202	2050403302	GSSS SERI KOTHI	MANDI	175038
203	2050406203	GSSS BEHLI	MANDI	175009

204	2050503002	GSSS GOKHRA	MANDI	175052
205	2050503703	GSSS NANAWAN	MANDI	175001
206	2050504202	GSSS RANDHARA	MANDI	175001
207	2050508102	GSSS BEER TUNGAL	MANDI	175001
208	2050700103	GSSS SAINJ	MANDI	175029
209	2050704402	GSSS DADOH	MANDI	175029
210	2050705602	GSSS BASSI	MANDI	175029
211	2050705902	GSSS KEOLO DHAR	MANDI	175029
212	2050708002	GSSS SHIKAWARI	MANDI	175035
213	2050800503	GSSS JHUNGI	MANDI	175031
214	2050805302	GSSS KILLING	MANDI	175028
215	2050806801	GSSS KATWAHCHI	MANDI	175046
216	2050900502	GSSS BAGA CHONOGI	MANDI	175035
217	2050901105	GSSS DHARWAR THACH	MANDI	175035
218	2050901404	GSSS SHIVA KUTHER	MANDI	175035
219	2050904502	GSSS JAROL	MANDI	175048
220	2050907502	GSSS BARYOGI	MANDI	175047
221	2050909102	GSSS CHEUNI	MANDI	175048
222	2050910602	GSSS MEHRI DHAR	MANDI	175047
223	2051000101	GSSS KHUNACHI	MANDI	175123
224	2051000303	GSSS KHOLANAL	MANDI	175124
225	2051000601	GSSS KHUHAN	MANDI	175106
226	2051000701	GSSS THACHHI	MANDI	175121
227	2051001001	GSSS GADA GUSAIN	MANDI	175123
228	2051001501	GSSS PANJAIN	MANDI	175106
229	2051001701	GSSS SOM NACHAN	MANDI	175121
230	2051001806	GSSS MURRAH	MANDI	175121
231	2051017001	GSSS SHARTI	MANDI	175124
232	2051017601	GSSS KASHIMBLIDHAR	MANDI	175124
233	2051102602	GSSS GUMMA	MANDI	175015
234	2051107103	GSSS NAUHALI	MANDI	175015
235	2051108102	GSSS BIHUN	MANDI	175015
236	2051108202	GSSS BASSI	MANDI	175015
237	2051116501	GSSS TIKROO	MANDI	175032
238	2051116901	GSSS THARTUKHOD	MANDI	175013
239	2051200102	GSSS URLA	MANDI	175015
240	2051206302	GSSS BATHERI	MANDI	175005
241	2051206802	GSSS TANDOO	MANDI	275001
242	2051213702	GSSS ROPA	MANDI	175012
243	2051301102	GSSS AHJU	MANDI	175032
244	2051303304	GSSS SAINTHAL	MANDI	175032
245	2051303502	GSSS NIMELARY	MANDI	175032

246	2051309802	GSSS KUTHEHRA	MANDI	175015
247	2051401202	GSSS GOLWAN	MANDI	175032
248	2051401702	GSSS BHARAR PATT	MANDI	175016
249	2051403002	GSSS BHAGHER LANGSAR	MANDI	175016
250	2051404802	GSSS PANJALAG	MANDI	175016
251	2051405102	GSSS KHUDDI	MANDI	175016
252	2051406102	GSSS TULLAH	MANDI	175015
253	2051502303	GSSS KAO	MANDI	175011
254	2051503101	GSSS BHANTHAL	MANDI	175011
255	2051503802	GSSS TEBAN	MANDI	175011
256	2051508002	GSSS KHANYOL BAGDA	MANDI	175011
257	2051508502	GSSS SOMA KOTHI	MANDI	175011
258	2051508902	GSSS SAINJ BAGDA	MANDI	175011
259	2051509801	GSSS SHANKAR DEHRA	MANDI	175011
260	2051601102	GSSS BAGRA MAHUN	MANDI	175010
261	2051610902	GSSS PRESSI	MANDI	175046
262	2051612603	GSSS BAGSHAR	MANDI	171303
263	2051614402	GSSS KANDHA	MANDI	175010
264	2051615502	GSSS TATTAPANI	MANDI	171302
265	2051621202	GSSS SHORSHAN	MANDI	175010
266	2051622302	GSSS JASSAL	MANDI	175009
267	2051701202	GSSS RAKHOH	MANDI	175042
268	2051706402	GSSS KHAHAN	MANDI	175049
269	2051706802	GSSS TIKKAR	MANDI	175049
270	2051707702	GSSS RAKHOTA	MANDI	175049
271	2051708002	GSSS MASSERAN	MANDI	175024
272	2051710902	GSSS DEV BRARTA	MANDI	175024
273	2051711003	GSSS SARKAGHAT (G)	MANDI	175024
274	2051715501	GSSS PAPLOG.	MANDI	175024
275	2051800902	GSSS SIDHWANI TIKKARI	MANDI	175004
276	2051807902	GSSS MAJHIATH	MANDI	175033
277	2051811102	GSSS TRIFALGHAT	MANDI	175034
278	2051901302	GSSS-SADHOT	MANDI	175037
279	2051905902	GSSS-GHARWASRA	MANDI	175025
280	2052000202	GSSS MORLA	MANDI	175024
281	2052000702	GSSS BRANG	MANDI	175024
282	2052001603	GSSS KOTHUWAN	MANDI	176090
283	2052004102	GSSS KAMLAH FORT	MANDI	175050
284	2052004802	GSSS TOUR KHOLA	MANDI	176090
285	2052006802	GSSS TANEHAR	MANDI	175050
286	2052007703	GSSS SAMOUR	MANDI	175050
287	2052009102	GSSS BAROTI	MANDI	175040

288	2052014601	GSSS SARI	MANDI	175025
289	2060100902	GSSS UTPUR	HAMIRPUR (H.P.)	177022
290	2060220505	GSSS BIR BAGEHRA	HAMIRPUR (H.P.)	176110
291	2060309802	GSSS BAHNWIN	HAMIRPUR (H.P.)	177118
292	2060408702	GSSS CHORU	HAMIRPUR (H.P.)	177044
293	2060505002	GSSS SOHARI	HAMIRPUR (H.P.)	174311
294	2060508102	GSSS KULHERA	HAMIRPUR (H.P.)	174311
295	2060508602	GSSS DANDRU	HAMIRPUR (H.P.)	174312
296	2060510405	GSSS GHANGOT	HAMIRPUR (H.P.)	176039
297	2060604902	GSSS UPPERLA HARETA	HAMIRPUR (H.P.)	174405
298	2060605802	GSSS BATRAN	HAMIRPUR (H.P.)	177042
299	2070100203	GSSS BALIWAL	UNA	177220
300	2070100404	GSSS BATHU	UNA	174301
301	2070100502	GSSS BEETON	UNA	176601
302	2070100804	GSSS BHADSALI	UNA	174317
303	2070101602	GSSS G/JAICHAND	UNA	176601
304	2070101802	GSSS HEERAN	UNA	176601
305	2070101904	GSSS ISPUR	UNA	174301
306	2070102502	GSSS KUNGRAT	UNA	172209
307	2070103102	GSSS NANGAL KHURD	UNA	174301
308	2070103304	GSSS PALKWAH	UNA	177220
309	2070104103	GSSS SINGAN	UNA	176601
310	2070104601	GSSS BADHERA	UNA	177209
311	2070104701	GSSS RORA SAINSOWAL	UNA	177220
312	2070200903	GSSS BASOLI	UNA	174303
313	2070201601	GSSS CHATTARA	UNA	174306
314	2070202502	GSSS JAKHERA	UNA	174315
315	2070203503	GSSS KUTHAR KALAN	UNA	174303
316	2070210903	GSSS KURIALA	UNA	174303
317	2070302102	GSSS JOH	UNA	177204
318	2070302302	GSSS KALOH	UNA	177201
319	2070302503	GSSS KUTHERA JASWALAN	UNA	177206
320	2070303006	GSSS MAWA KAHOLAN	UNA	177204
321	2070303906	GSSS PIRTHIPUR	UNA	177204

322	2070401701	CAKMGSSS CHINTPURNI	UNA	177110
323	2070401902	GSSS DALOH	UNA	177203
324	2070402602	GSSS GHANGRET	UNA	177110
325	2070402802	GSSS GINDPUR MALAUN	UNA	177110
326	2070405102	GSSS SALOI	UNA	177203
327	2070500903	GSSS BADOLI	UNA	174302
328	2070501403	GSSS BEHAR JASWAN	UNA	177211
329	2070504002	GSSS JOWAR	UNA	177210
330	2070505902	GSSS NEHRIAN	UNA	177210
331	2070601302	GSSS BOUL	UNA	174321
332	2070604002	GSSS PIPLOO	UNA	177041
333	2070610302	GSSS MANDALI	UNA	174321
334	2080101902	GSSS CHANDPUR	BILASPUR (H.P.)	174001
335	2080108003	GSSS HARNORA	BILASPUR (H.P.)	174036
336	2080109902	GSSS RANIKOTLA	BILASPUR (H.P.)	174033
337	2080111504	GSSS BANDLA	BILASPUR (H.P.)	174001
338	2080112402	GSSS RAGHUNATHPURA	BILASPUR (H.P.)	174005
339	2080115102	GSSS DEOTH	BILASPUR (H.P.)	174001
340	2080121702	GSSS SUIN SURHAR	BILASPUR (H.P.)	174033
341	2080123002	GSSS SOHRI	BILASPUR (H.P.)	174032
342	2080123402	GSSS SIKROHA	BILASPUR (H.P.)	174032
343	2080124002	GSSS CHHAKOH	BILASPUR (H.P.)	174001
344	2080201002	GSSS NANGAY THAKUR	BILASPUR (H.P.)	174011
345	2080201507	GSSS MANJARI	BILASPUR (H.P.)	174002
346	2080202602	GSSS TOBA	BILASPUR (H.P.)	174002
347	2080205203	GSSS DHULET	BILASPUR (H.P.)	174002
348	2080206703	GSSS SALOA	BILASPUR (H.P.)	174201
349	2080208501	GSSS NAKRANA	BILASPUR (H.P.)	174310
350	2080209702	GSSS TARWAR	BILASPUR (H.P.)	174310
351	2080209904	GSSS BEHAL	BILASPUR (H.P.)	174015
352	2080212902	GSSS KATHALA	BILASPUR (H.P.)	174011
353	2080213702	GSSS TANBAUL	BILASPUR (H.P.)	174011
354	2080218903	GSSS CHHAROL	BILASPUR (H.P.)	174014
355	2080219402	GSSS BADDU (DADHOG)	BILASPUR (H.P.)	174001
356	2080302002	GSSS JADDU KULZIAR	BILASPUR (H.P.)	174030
357	2080302604	GSSS BHERI	BILASPUR (H.P.)	174035
358	2080303501	GSSS MALRAON	BILASPUR (H.P.)	174035
359	2080308402	GSSS SALWAR	BILASPUR (H.P.)	174017
360	2080310402	GSSS NAKHLERA	BILASPUR (H.P.)	174034
361	2080312702	GSSS DAHAD	BILASPUR (H.P.)	174034
362	2080313702	GSSS SUNHANI	BILASPUR (H.P.)	174029
363	2080317302	GSSS KOSERIAN	BILASPUR (H.P.)	174030

364	2080319903	GSSS DASLEHRA	BILASPUR (H.P.)	174030
365	2080320102	GSSS GHANDHIR	BILASPUR (H.P.)	174029
366	2080401402	GSSS KOT	BILASPUR (H.P.)	174028
367	2080403104	GSSS MARHANA	BILASPUR (H.P.)	174028
368	2080406604	GSSS BAROTA	BILASPUR (H.P.)	174027
369	2080406702	GSSS DUMEHAR	BILASPUR (H.P.)	174027
370	2080412802	GSSS MORSINGHI	BILASPUR (H.P.)	174026
371	2080419102	GSSS DADHOL	BILASPUR (H.P.)	174023
372	2080419803	GSSS GALLIAN	BILASPUR (H.P.)	174029
373	2080501403	GSSS MALYAWER	BILASPUR (H.P.)	174004
374	2080502102	GSSS BALH CHURANI	BILASPUR (H.P.)	174003
375	2080502301	GSSS GOAL MUTHANI	BILASPUR (H.P.)	174013
376	2080504202	GSSS KUH MAJHWAR	BILASPUR (H.P.)	174003
377	2080505301	GSSS BARDHIN	BILASPUR (H.P.)	174003
378	2080506202	GSSS HAWAN	BILASPUR (H.P.)	174003
379	2080517003	GSSS DHANETTAR	BILASPUR (H.P.)	174034
380	2090100401	GSSS PATTI BRAWARI	SOLAN	173207
381	2090101101	GSSS DELGI	SOLAN	173206
382	2090101201	GSSS GHAIGHAT	SOLAN	173229
383	2090101301	GSSS KOTI	SOLAN	173207
384	2090101501	GSSS KOTHI DEORA	SOLAN	173211
385	2090101601	GSSS MANJHOL (D)	SOLAN	173220
386	2090101701	GSSS PRATHA	SOLAN	173220
387	2090102001	GSSS KANDA	SOLAN	173209
388	2090102101	GSSS PATTI MASUL KHANA	SOLAN	173220
389	2090102201	GSSS BHOJNAGAR	SOLAN	173229
390	2090200801	GSSS BADHALAG	SOLAN	173218
391	2090200901	GSSS KOT BEJA	SOLAN	173233
392	2090310501	GSSS SYRI	SOLAN	173207
393	2090312101	GSSS DOMEHAR	SOLAN	172034
394	2090312401	GSSS CHHAUSHA	SOLAN	173234
395	2090312501	GSSS KAWARAG	SOLAN	173215
396	2090312601	GSSS KADAUR	SOLAN	173234
397	2090313201	GSSS BISHA	SOLAN	173234
398	2090401001	GSSS BHATIAN	SOLAN	174101
399	2090402501	GSSS RATWARI	SOLAN	174101
400	2090402601	GSSS LOHARGHAT	SOLAN	174102
401	2090414201	GSSS BAGHERI	SOLAN	174101
402	2090414801	GSSS BAHA	SOLAN	174101
403	2090414901	GSSS NAND	SOLAN	174102
404	2090415001	GSSS DOLI	SOLAN	174102
405	2090415202	GSSS MITTIAN	SOLAN	174102

406	2090415501	GSSS RERU	SOLAN	174101
407	2090505601	GSSS SURAJPUR	SOLAN	173235
408	2090505801	GSSS BALERA	SOLAN	173221
409	2090505901	GSSS SARYANJ	SOLAN	173235
410	2090506101	GSSS BANI MATERNI	SOLAN	173221
411	2090506301	GSSS MANGAL	SOLAN	171102
412	2090506401	GSSS NAVGAON	SOLAN	171102
413	2090600602	GSSS DOMEHAR- A	SOLAN	173221
414	2090602902	GSSS MANJOO	SOLAN	173208
415	2090606502	GSSS CHANDI	SOLAN	171102
416	2090608101	GSSS BATHALANG	SOLAN	173207
417	2090700501	GSSS MANJHOLI	SOLAN	174101
418	2090700601	GSSS SAUR	SOLAN	174102
419	2090700901	GSSS GOELA PANNER	SOLAN	174101
420	2090702901	GSSS SAI	SOLAN	173205
421	2090703001	GSSS KHERA NANOWAL	SOLAN	174101
422	2090703101	GSSS CHHIACHHI	SOLAN	174102
423	2100100102	GSSS BAKRAS	SIRMAUR	173029
424	2100100804	GSSS MILLAH	SIRMAUR	173029
425	2100101403	GSSS HALLHAN	SIRMAUR	713027
426	2100101704	GSSS PANOG	SIRMAUR	173027
427	2100101903	GSSS JARWA JUNELI	SIRMAUR	173027
428	2100102403	GSSS SANGNA SATAHAN	SIRMAUR	173023
429	2100104205	GSSS KOTI DHIMAN	SIRMAUR	173022
430	2100200803	GSSS LANA PALLAR	SIRMAUR	173023
431	2100201502	GSSS BADAG	SIRMAUR	173023
432	2100202102	GSSS RAJANA	SIRMAUR	173023
433	2100304102	GSSS PANJAHAL	SIRMAUR	173001
434	2100305002	GSSS BIRLA	SIRMAUR	173022
435	2100400104	GSSS NOHRADHAR	SIRMAUR	173104
436	2100400602	GSSS GHANDOORI	SIRMAUR	173104
437	2100401502	GSSS LANA CHETA	SIRMAUR	173104
438	2100402503	GSSS SER TANDULA	SIRMAUR	173104
439	2100404302	GSSS HARIPURDHAR	SIRMAUR	173023
440	2100405706	GSSS LUDHIYANA	SIRMAUR	173023
441	2100500703	GSSS GORKHOOWALA	SIRMAUR	173025
442	2100501202	GSSS AJOLI	SIRMAUR	173025
443	2100501303	GSSS NIHALGARH	SIRMAUR	173025
444	2100503604	GSSS JAMNIWALA	SIRMAUR	173025
445	2100600104	GSSS DEOTHI MAJHGAON	SIRMAUR	171226
446	2100600404	GSSS DHARAMPUR	SIRMAUR	171226
447	2100600702	GSSS BHAROLI	SIRMAUR	171226

448	2100601002	GSSS SHARGAON	SIRMAUR	173223
449	2100601902	GSSS SAINYO DEEDAG	SIRMAUR	173101
450	2100604602	GSSS HABBAN	SIRMAUR	173101
451	2100606102	GSSS SANORA	SIRMAUR	173223
452	2100607302	GSSS JADOL TAPROLI	SIRMAUR	173223
453	2100608702	GSSS CHAMBI DHAR	SIRMAUR	173101
454	2100702402	GSSS GALANAGHAT	SIRMAUR	173024
455	2100704602	GSSS KALOH	SIRMAUR	173024
456	2100707302	GSSS BAGHTHAN	SIRMAUR	173001
457	2100713202	GSSS GAGAL SHIKOR	SIRMAUR	173001
458	2100800902	GSSS CHANDNI	SIRMAUR	173022
459	2100801403	GSSS KATHWAR	SIRMAUR	173022
460	2100801802	GSSS KORGA	SIRMAUR	173029
461	2100802606	GSSS KANTI MASHWA	SIRMAUR	173029
462	2100804802	GSSS KILLAOUR	SIRMAUR	173025
463	2100900604	GSSS KANDIYARI	SIRMAUR	173027
464	2100901105	GSSS TIMBI	SIRMAUR	173029
465	2100901608	GSSS BANDLI DADAS	SIRMAUR	173027
466	2100901903	GSSS DRABIL	SIRMAUR	173027
467	2100902103	GSSS NAINI DHAR	SIRMAUR	173027
468	2100902803	GSSS KOTI BOUNCH	SIRMAUR	173027
469	2101001202	GSSS BANETHI	SIRMAUR	173001
470	2101001702	GSSS CHAKLI	SIRMAUR	173001
471	2101002702	GSSS K. W. BHOOD	SIRMAUR	173026
472	2101003002	GSSS BURMA PAPRI	SIRMAUR	173030
473	2101003402	GSSS PALLION	SIRMAUR	173030
474	2101004402	GSSS MOGINAND	SIRMAUR	173030
475	2101004703	GSSS KALA AMB	SIRMAUR	173030
476	2101100312	GSSS TATIYANA	SIRMAUR	173029
477	2101101205	GSSS KAMRAU	SIRMAUR	173029
478	2101101905	GSSS JAMNA	SIRMAUR	173029
479	2101102305	GSSS BANOUR	SIRMAUR	173025
480	2101200202	GSSS KUJJI	SIRMAUR	173229
481	2101202702	GSSS MANGARH	SIRMAUR	173024
482	2101203402	GSSS JAIHER	SIRMAUR	173024
483	2101203802	GSSS BASAHAN	SIRMAUR	173001
484	2101205703	GSSS WASNI	SIRMAUR	173024
485	2101300502	GSSS BHAROG BHANERI	SIRMAUR	173022
486	2101301002	GSSS (GIRLS) PIPLIWALA	SIRMAUR	173025
487	2101301302	GSSS PURUWALA	SIRMAUR	173001
488	2101301502	GSSS RAMPUR BHARAPUR	SIRMAUR	173001
489	2110100102	GSSS KALOTI	SHIMLA	171207

490	2110101702	GSSS MASLI	SHIMLA	171208
491	2110108102	GSSS GAONSARI	SHIMLA	171208
492	2110200902	GSSS KHADDAR	SHIMLA	171211
493	2110203002	GSSS PULBAHAL	SHIMLA	171226
494	2110203602	GSSS SARI	SHIMLA	171226
495	2110204102	GSSS NANHAR	SHIMLA	171211
496	2110204902	GSSS MATAL	SHIMLA	171211
497	2110301602	GSSS GHOOND	SHIMLA	171220
498	2110304302	GSSS BALAG	SHIMLA	171226
499	2110305002	GSSS BASADHAR	SHIMLA	171226
500	2110401501	GSSS KEWAR	SHIMLA	171221
501	2110500102	GSSS GILTARI	SHIMLA	171216
502	2110500702	GSSS SOLANG	SHIMLA	171206
503	2110502302	GSSS RATHAL	SHIMLA	171216
504	2110503302	GSSS DADI-RAWAT	SHIMLA	171206
505	2110503702	GSSS SANSOG	SHIMLA	171206
506	2110503802	GSSS NANDPUR	SHIMLA	171206
507	2110504902	GSSS DEEM	SHIMLA	171205
508	2110505202	GSSS BARTHATA	SHIMLA	171206
509	2110505702	GSSS DHAR	SHIMLA	171205
510	2110505902	GSSS SAROT	SHIMLA	171205
511	2110507602	GSSS JHARAG NAKRARI	SHIMLA	171206
512	2110603202	GSSS SHAKRAHA	SHIMLA	171011
513	2110604202	GSSS BEOLIA	SHIMLA	171009
514	2110604702	GSSS KIAR KOTI	SHIMLA	171007
515	2110606501	GSSS OKHROO	SHIMLA	171103
516	2110700502	GSSS RAM NAGAR	SHIMLA	171202
517	2110701702	GSSS DEVGARH	SHIMLA	171202
518	2110701802	GSSS BAGI	SHIMLA	171225
519	2110703402	GSSS SAINTARI	SHIMLA	171202
520	2110703803	GSSS GUMMA	SHIMLA	171202
521	2110704902	GSSS THAROLA	SHIMLA	171202
522	2110706002	GSSS JAUNI	SHIMLA	171202
523	2110706802	GSSS RAWLA-KIAR	SHIMLA	171202
524	2110709203	GSSS RATNARI	SHIMLA	171225
525	2110709602	GSSS HIMRI	SHIMLA	171202
526	2110710002	GSSS PURAG	SHIMLA	171202
527	2110802802	GSSS SHAMATHLA	SHIMLA	172030
528	2110804002	GSSS KOTGARH	SHIMLA	172031
529	2110804102	GSSS MAILAN	SHIMLA	172031
530	2110805602	GSSS MALENDI	SHIMLA	172029
531	2110807703	GSSS SHIWAN	SHIMLA	172027

532	2110900103	GSSS DHALLI	SHIMLA	170012
533	2110900602	GSSS KUFRI	SHIMLA	171012
534	2110901302	GSSS DUBLOO	SHIMLA	173217
535	2110901402	GSSS GUMMA	SHIMLA	171018
536	2110902102	GSSS JANEDGHAT	SHIMLA	173217
537	2110903002	GSSS PIRAN	SHIMLA	173217
538	2110903802	GSSS MUNDAGHAT	SHIMLA	171012
539	2110905802	GSSS KOTI	SHIMLA	171012
540	2110907702	GSSS BHATTAKUFAR(KAMLANAGAR)	SHIMLA	171006
541	2111002402	GSSS MAHORI	SHIMLA	171220
542	2111002702	GSSS DHARAMPUR	SHIMLA	171201
543	2111003202	GSSS GADAKUFRI	SHIMLA	171201
544	2111003802	GSSS NAG JUBBER	SHIMLA	171212
545	2111005201	GSSS KIARA	SHIMLA	171213
546	2111100602	GSSS KHUNNI	SHIMLA	171213
547	2111102003	GSSS BAGALTI	SHIMLA	172021
548	2111103602	GSSS CHARI-DHARAN	SHIMLA	172021
549	2111105402	GSSS M/TIPPER	SHIMLA	172001
550	2111107102	GSSS KUNGALBALTI	SHIMLA	172001
551	2111108302	GSSS THALI CHAKTI	SHIMLA	172001
552	2111201302	GSSS HALAU	SHIMLA	171210
553	2111202202	GSSS PABAN	SHIMLA	171210
554	2111202702	GSSS SHILLA	SHIMLA	171210
555	2111204002	GSSS MANEOTI	SHIMLA	171210
556	2111207502	GSSS TIKKARI	SHIMLA	171210
557	2111209902	GSSS KEDI	SHIMLA	171210
558	2111214502	GSSS RUSLAH	SHIMLA	171210
559	2111215502	GSSS IRRA	SHIMLA	171210
560	2111215801	GSSS PAURIA	SHIMLA	171211
561	2111302202	GSSS DEOTHI	SHIMLA	172022
562	2111303902	GSSS SHINGLA	SHIMLA	172001
563	2111306402	GSSS DANSA	SHIMLA	172001
564	2111310102	GSSS NARAIN	SHIMLA	172022
565	2111312402	GSSS BAHALI	SHIMLA	172022
566	2111401102	GSSS Balsa(KANSA KOTI)	SHIMLA	171207
567	2111401302	GSSS MACHOTI	SHIMLA	171207
568	2111403102	GSSS KARASA	SHIMLA	171207
569	2111404702	GSSS KUI(BACHHUNCH)	SHIMLA	171207
570	2111405202	GSSS KUTARA	SHIMLA	171207
571	2111405402	GSSS DALGAON	SHIMLA	171207
572	2111409602	GSSS BARTU	SHIMLA	171207

573	2111411702	GSSS SUMMERKOT	SHIMLA	171224
574	2111500302	GSSS BYCHARI	SHIMLA	171011
575	2111501003	GSSS BOILAEUGANJ	SHIMLA	171005
576	2111502202	GSSS BHOUNT	SHIMLA	171003
577	2111600802	GSSS CHALAL	SHIMLA	171103
578	2111601402	GSSS DHAROGRA	SHIMLA	171019
579	2111602502	GSSS KHAIRA	SHIMLA	171018
580	2111604702	GSSS THAILA (SHAHEED N.K)	SHIMLA	171007
581	2111605102	GSSS GHAINI	SHIMLA	171007
582	2111608102	GSSS OGLI	SHIMLA	171019
583	2111609402	GSSS KARYALI	SHIMLA	171018
584	2111700102	GSSS SAINJ	SHIMLA	171220
585	2111708001	GSSS CHEOG	SHIMLA	171209
586	2111802002	GSSS DHAR-CHANDNA	SHIMLA	171210
587	2111802302	GSSS MALAT	SHIMLA	171210
588	2111803501	GSSS GAUNTH	SHIMLA	171217
589	2111902102	GSSS GANVI 15/20	SHIMLA	172101
590	2111904201	GSSS KINNU	SHIMLA	172102
591	2111905401	GSSS DOFDA	SHIMLA	172102
592	2112000602	GSSS BADSHAL	SHIMLA	171203
593	2112000802	GSSS PUJARLI-3	SHIMLA	171203
594	2112001803	GSSS SHEEL	SHIMLA	171205
595	2112002302	GSSS KUTHARI	SHIMLA	171203
596	2120100501	G.S.S.S. URNI	KINNAUR	172104
597	2120101301	GSSS CHAGAON	KINNAUR	172104
598	2120101401	GSSS RUPI	KINNAUR	171101
599	2120101601	GSSS NIGULSARI	KINNAUR	172101
600	2120102401	G.S.S.S MIROO	KINNAUR	172104
601	2120104501	GSSS CHHOTA KAMBA	KINNAUR	172101
602	2120200201	G.S.S.S. KILBA	KINNAUR	172105
603	2120201201	G.S.S.S. SAPNI	KINNAUR	172105
604	2120201701	DEVI CHANDIKA G.S.S.S. KOTHI	KINNAUR	172107
605	2120203801	GSSS RAKCHHAM	KINNAUR	172106
606	2120206002	GSSS PANGI	KINNAUR	172108
607	2120207901	GSSS TANGLING	KINNAUR	172107
608	2120300102	G.S.S.S. RIBBA	KINNAUR	172116
609	2120300301	GSSS LIPPA	KINNAUR	172109
610	2120300401	G.S.S.S. GIABONG	KINNAUR	172110
611	2120300801	G.S.S.S. LIYO	KINNAUR	172112
612	2120301701	MASTER RAMJI DASS GSSS RARANG	KINNAUR	172116
613	2120301801	GSSS JANGI	KINNAUR	172109

614	2120302001	G.S.S.S. CHANGO	KINNAUR	172111
615	2120302501	G.S.S.S. MOORANG	KINNAUR	172109

List of 835 Govt. High Schools

Sr.	UDISE CODE	Name of the School	District	PIN CODE
1	2010101702	GHS GUNIALA	CHAMBA	176306
2	2010101902	GHS NIGALI	CHAMBA	176303
3	2010104702	GHS BALERA	CHAMBA	176301
4	2010105302	GHS CHUHAN	CHAMBA	176303
5	2010107102	GHS SAMLEU	CHAMBA	176325
6	2010200202	GHS BADGRAM	CHAMBA	176324
7	2010200502	GHS SIUR	CHAMBA	176309
8	2010200803	GHS KUGTI	CHAMBA	176315
9	2010202204	GGHS BHARMOUR	CHAMBA	176315
10	2010203102	GHS AURA	CHAMBA	176324
11	2010203602	GHS CHOBIA	CHAMBA	176315
12	2010302002	GHS SILLAGHARAT	CHAMBA	176314
13	2010302602	GHS SINGI	CHAMBA	176310
14	2010303902	GHS SACH	CHAMBA	176310
15	2010304602	GHS PARIHAR	CHAMBA	176306
16	2010305802	GHS CHEEL BANGLA	CHAMBA	176306
17	2010306203	GHS PANJOH	CHAMBA	176310
18	2010306602	GHS PALURE	CHAMBA	176314
19	2010308501	GHS PUCCATALA	CHAMBA	176310
20	2010400902	GHS GAGAHAR	CHAMBA	176302
21	2010401702	GHS DHADU	CHAMBA	176302
22	2010404902	GHS GHATASNI	CHAMBA	176301
23	2010405502	GHS BHARARI	CHAMBA	176301
24	2010406302	GHS AWANH	CHAMBA	176313
25	2010406702	GHS BAHU KA BAG	CHAMBA	176302
26	2010500402	GHS DEYOL	CHAMBA	176309
27	2010501402	GHS DURGETHI	CHAMBA	176324
28	2010501702	GHS NAYAGRAN	CHAMBA	176326
29	2010502902	GHS ULANSA	CHAMBA	176309
30	2010504802	GHS LAMU	CHAMBA	176309

31	2010600102	GHS RAJERA	CHAMBA	176310
32	2010601802	GHS KADED	CHAMBA	176314
33	2010603102	GHS GAGLA	CHAMBA	176311
34	2010603502	GSSS BHARIAN KOTHI	CHAMBA	176318
35	2010605702	GHS BAAT	CHAMBA	176314
36	2010608001	GHS JAMUHAR	CHAMBA	176314
37	2010608101	GHS KUMHARKA	CHAMBA	176310
38	2010608201	GHS MANGLA	CHAMBA	176314
39	2010608301	GHS KOLKA	CHAMBA	176314
40	2010700503	GHS RAJNAGAR	CHAMBA	176310
41	2010701402	GHS SANDHI	CHAMBA	176319
42	2010704303	GHS MAUWA	CHAMBA	176319
43	2010705202	GHS KANDLA	CHAMBA	176319
44	2010801102	GHS GURAD	CHAMBA	176311
45	2010801402	GHS SAMRA	CHAMBA	176311
46	2010804602	GHS TRALLA	CHAMBA	176311
47	2010804702	GHS DHULLARA	CHAMBA	176311
48	2010808202	GHS CHOORI	CHAMBA	176311
49	2010900103	GHS SURAL	CHAMBA	176323
50	2010900302	GHS KUMAR	CHAMBA	176323
51	2010901302	GHS TUNDROO	CHAMBA	176323
52	2010901602	GHS KARYOONI	CHAMBA	176323
53	2010903302	GHS SAHALI	CHAMBA	176323
54	2010904702	GHS REI	CHAMBA	176323
55	2011000302	GHS SURANGANI	CHAMBA	176317
56	2011000702	GSSS DAND	CHAMBA	176320
57	2011000902	GHS MANGLI	CHAMBA	176321
58	2011001202	GHS AIL	CHAMBA	176316
59	2011001802	GHS LAHRA	CHAMBA	176321
60	2011008901	GHS SANGHANI	CHAMBA	176320
61	2011101002	GHS MANHUTA	CHAMBA	176302
62	2011103002	GHS GARNOTA	CHAMBA	176207
63	2011103405	GGHS SIHUNTA	CHAMBA	176207
64	2011107002	GHS DADRIARA	CHAMBA	176302
65	2011107702	GHS MORTHU	CHAMBA	176207
66	2011108102	GHS BANETA	CHAMBA	176207
67	2011200802	GHS ATHER	CHAMBA	176312
68	2011201002	GHS BHUNAD	CHAMBA	176325
69	2011201202	GHS NADAL	CHAMBA	176325
70	2011201702	GHS LIGGA	CHAMBA	176325
71	2011203602	GHS BHAJOTRA	CHAMBA	176312
72	2011208501	GHS PAJJA	CHAMBA	176308

73	2011302102	GHS SEI KOTHI	CHAMBA	176316
74	2011302202	GHS BONDERI	CHAMBA	176316
75	2011303802	GHS THANEI	CHAMBA	176316
76	2011307402	GHS DEVI KOTHI	CHAMBA	176316
77	2011312501	GHS GANED	CHAMBA	176316
78	2011402203	GHS BREHI	CHAMBA	176324
79	2011405102	GHS KUNRA	CHAMBA	176324
80	2011405401	GHS KUTHER	CHAMBA	176324
81	2011501302	GHS BAGHEIGARH	CHAMBA	176321
82	2011501402	GHS CHARDA	CHAMBA	176321
83	2011502702	GHS RAILLA	CHAMBA	176319
84	2011503402	GHS THALLI	CHAMBA	176321
85	2011503602	GHS CHILLI	CHAMBA	176321
86	2011506101	GHS KOHAL	CHAMBA	176319
87	2020100202	GHS BAH I	KANGRA	176125
88	2020101002	GHS BHETH JHIKLI	KANGRA	176081
89	2020101602	GHS CHOBIN	KANGRA	176128
90	2020101903	GHS MULTHAN	KANGRA	175013
91	2020102002	GHS DHANAG	KANGRA	176125
92	2020103502	GHS HARER	KANGRA	176115
93	2020108602	GHS PAPROLA(G)	KANGRA	176125
94	2020109702	GHS SEHAL	KANGRA	176125
95	2020111301	GHS MAJHERNA	KANGRA	176063
96	2020200702	GHS BARI	KANGRA	176083
97	2020201802	GHS CHOWKI	KANGRA	176084
98	2020202802	GHS GAGGAL	KANGRA	176101
99	2020204101	GHS BHODA	KANGRA	176092
100	2020205502	GHS LOWER KHERA	KANGRA	176072
101	2020206302	GHS MARHOON	KANGRA	176092
102	2020206702	GHS NANAON	KANGRA	176085
103	2020207302	GHS PUNNER	KANGRA	176083
104	2020207401	GHS PURBA	KANGRA	176084
105	2020207901	GHS SALOH	KANGRA	176102
106	2020209502	GHS USCHAR	KANGRA	176101
107	2020303502	GHS SALEHRA	KANGRA	176088
108	2020401502	GHS BARI	KANGRA	176502
109	2020402002	GHS BEH DHAUNTA	KANGRA	177105
110	2020402301	GSSS BEHIN	KANGRA	177103
111	2020404202	GHS GHATI BILWAN	KANGRA	176501
112	2020405302	GSSS JAMBAL	KANGRA	177113
113	2020405402	GHS JANDOUR	KANGRA	176501
114	2020408202	GHS NIAR	KANGRA	177112

115	2020408601	GHS PRAGPUR (G)	KANGRA	177107
116	2020409002	GHS RORI KORI	KANGRA	177113
117	2020409101	GHS SAMNOLI	KANGRA	177110
118	2020409802	GHS SUKHAHAR	KANGRA	177103
119	2020410302	GHS SWANA	KANGRA	177110
120	2020410601	GHS TIAMAL	KANGRA	177113
121	2020500602	GHS BANHE DI HATTI	KANGRA	176029
122	2020501103	GHS BARIKALAN	KANGRA	176055
123	2020502202	GHS BONGTA	KANGRA	177101
124	2020502902	GHS DEHRA(G)	KANGRA	177101
125	2020503002	GHS DHATTI	KANGRA	176031
126	2020503202	GHS DHAWALA	KANGRA	177101
127	2020503702	GHS DOLA KARYANA	KANGRA	176030
128	2020504002	GHS GHER	KANGRA	177114
129	2020504102	GHS GUMMER	KANGRA	177116
130	2020504306	GHS HARIPUR (G)	KANGRA	176028
131	2020504603	GHS JAWALAMUKHI(G)	KANGRA	176031
132	2020602312	GHS KB DHARMSALA	KANGRA	176215
133	2020604201	GHS KANED	KANGRA	176001
134	2020604502	GHS KASBA NARWANA	KANGRA	176052
135	2020606902	GHS SIDHBARI	KANGRA	176057
136	2020607501	GHS SUKKAR	KANGRA	176057
137	2020607901	GHS TOTARANI	KANGRA	176216
138	2020700402	GHS BADIALI	KANGRA	176053
139	2020706202	GHS MALHANTA	KANGRA	176058
140	2020706502	GHS MANOH-SIHAL	KANGRA	176053
141	2020709701	GHS CHHATTER	KANGRA	176022
142	2020709801	GHS DINILARTH	KANGRA	176022
143	2020803802	GHS GHORAN	KANGRA	176402
144	2020804202	GHS INDORA(G)	KANGRA	176401
145	2020804503	GHS BARI KANDRORI	KANGRA	176402
146	2020805702	GHS MAND MIANI	KANGRA	176403
147	2020806603	GHS PARAL	KANGRA	176403
148	2020807002	GHS RIALI	KANGRA	176058
149	2020807102	GHS SAHOURA	KANGRA	176204
150	2020808402	GHS TATWALI	KANGRA	176058
151	2020900802	GHS BHALLAD	KANGRA	176023
152	2020902002	GHS NANA HAR	KANGRA	176023
153	2020902704	GHS JAWALI(G)	KANGRA	176023
154	2020903702	GHS TAHLIAN	KANGRA	176023
155	2021000702	GHS BANDAL	KANGRA	176029
156	2021001402	GHS BIRTA	KANGRA	176001

157	2021002301	GHS DEHRIAN	KANGRA	176214
158	2021003502	GHS ICHHI	KANGRA	176209
159	2021003602	GHS JALARI	KANGRA	176038
160	2021003702	GHS JANDRAH	KANGRA	176054
161	2021004904	GHS KHARAT	KANGRA	176054
162	2021005103	GHS KHOLI	KANGRA	176056
163	2021005201	GHS KOHALA	KANGRA	176001
164	2021005502	GHS KULTHI	KANGRA	176038
165	2021006102	GHS NANDHER	KANGRA	176001
166	2021007303	GHS SOHRA	KANGRA	176209
167	2021007502	GHS SAKOUT	KANGRA	176001
168	2021008102	GHS SAMIRPUR	KANGRA	176214
169	2021008703	GHS TAKIPUR	KANGRA	176038
170	2021009001	GHS THAKURDWARA	KANGRA	176029
171	2021009101	GHS THANA BARAGRAN	KANGRA	176037
172	2021100302	GHS ASHAPURI	KANGRA	176094
173	2021100501	GHS BAIRGHATT	KANGRA	176073
174	2021101202	GHS BARRAM	KANGRA	176097
175	2021104402	GHS DRAMAN	KANGRA	176094
176	2021104602	GHS DUHAK	KANGRA	176075
177	2021105101	GHS HALER	KANGRA	176091
178	2021105302	GHS HARROT	KANGRA	176095
179	2021105402	GHS HARSİ	KANGRA	176091
180	2021106602	GHS KARANGHAT	KANGRA	176095
181	2021111201	GHS UPPER LAMBAGAON	KANGRA	176096
182	2021200603	GHS BALDHAR	KANGRA	176047
183	2021202302	GHS HATWAS	KANGRA	176047
184	2021202502	GHS JANDRANGAL	KANGRA	176052
185	2021202602	GHS JALOT	KANGRA	176047
186	2021202802	GHS JASSOUR	KANGRA	176056
187	2021204703	GHS LUHNA MAGRELA	KANGRA	176037
188	2021204802	GHS MALAN	KANGRA	176047
189	2021205002	GHS MASSAL	KANGRA	176047
190	2021205302	GHS MOOMTA	KANGRA	176047
191	2021206102	GHS PĻAH CHAKLU	KANGRA	176056
192	2021206802	GHS SAROTRI	KANGRA	176037
193	2021207602	GHS TANGROTI	KANGRA	176052
194	2021300202	GHS BALDOA	KANGRA	176023
195	2021301202	GHS BILASPUR	KANGRA	176033
196	2021301602	GHS DHAR DANGER	KANGRA	176033
197	2021302302	GHS GULER	KANGRA	176033
198	2021303902	GHS NANDPUR BHATOLI	KANGRA	176033

199	2021304602	GHS SPAIL	KANGRA	176026
200	2021402002	GHS BEHI-PATHIAR	KANGRA	176205
201	2021405102	GHS GAHIN LAGORE	KANGRA	176202
202	2021406002	GHS HATLI JAMWAL	KANGRA	176200
203	2021406102	GHS JACHH	KANGRA	176201
204	2021406402	GHS JAUNTA	KANGRA	176205
205	2021406601	GHS KHERIAN	KANGRA	176200
206	2021408002	GHS KOPRA	KANGRA	176202
207	2021408102	GHS KOT PLAHRI	KANGRA	176200
208	2021408302	GSSS KUKHER	KANGRA	176211
209	2021409602	GHS NADHOLI	KANGRA	176225
210	2021410701	GHS BADHUHI	KANGRA	176201
211	2021410804	GHS RAJA KA BAAG	KANGRA	176201
212	2021411001	GHS RINNA	KANGRA	176200
213	2021412003	GHS SOLDHA	KANGRA	176225
214	2021501502	GHS CHAMBI	KANGRA	176065
215	2021502002	GHS DEHAN	KANGRA	176102
216	2021503502	GHS JIA	KANGRA	176059
217	2021505502	GHS MEHNJHA	KANGRA	176061
218	2021506303	GHS RAKH	KANGRA	176059
219	2021506703	GHS SIDHPUR SARKARI	KANGRA	176064
220	2021507901	GHS JHARET	KANGRA	176060
221	2021600203	GHS ANDRETTA	KANGRA	176061
222	2021601802	GHS CHANDPUR	KANGRA	176061
223	2021607102	GHS SALIANA	KANGRA	176103
224	2021609802	GHS TIKARI	KANGRA	176063
225	2021610601	GHS THANDOL	KANGRA	176087
226	2021701002	GHS BHADIARA	KANGRA	176209
227	2021701402	GHS BHANALA	KANGRA	176206
228	2021701802	GHS BHATECHH	KANGRA	176217
229	2021702101	GHS BHITLU	KANGRA	176217
230	2021703002	GHS DADHAMB	KANGRA	176208
231	2021703301	GHS DHARKALAN	KANGRA	176210
232	2021706002	GHS KETLU	KANGRA	176208
233	2021706403	GHS SUKHUGHAT	KANGRA	176217
234	2021706601	GHS LADWARA	KANGRA	176208
235	2021707302	GHS LAPIANA	KANGRA	176210
236	2021708502	GHS NERTI	KANGRA	176208
237	2021709302	GHS PREI	KANGRA	176208
238	2021710202	GHS SADDUN	KANGRA	176206
239	2021710702	GHS SARAH	KANGRA	176215
240	2021800202	GHS BANOLI	KANGRA	176200

241	2021801902	GHS CHARURI	KANGRA	176051
242	2021802402	GHS DAGLA	KANGRA	176204
243	2021803002	GHS DHANETI	KANGRA	176051
244	2021803806	GHS GANGATH(G)	KANGRA	176204
245	2021804102	GHS GHETA	KANGRA	176204
246	2021804301	GHS GOLWAN	KANGRA	176022
247	2021805602	GHS MANGWAL	KANGRA	176204
248	2021807002	GHS RIT	KANGRA	176201
249	2021900101	GHS ADHWANI	KANGRA	176036
250	2021900202	GHS ALOH	KANGRA	177034
251	2021901101	GHS BHAROLI JADID	KANGRA	177043
252	2021902102	GSSS GAGRUHI	KANGRA	176036
253	2021903403	GHS GARLI(G)	KANGRA	177108
254	2021904502	GHS KALOHA	KANGRA	177043
255	2021905201	GHS KHUNA	KANGRA	177043
256	2021908302	GHS SARD DOGRI	KANGRA	177043
257	2021908901	GHS SIALKAR	KANGRA	176032
258	2021909102	GHS SUDHANGAL	KANGRA	176036
259	2021909901	GHS UPPER SEHRI	KANGRA	177108
260	2030200102	GHS MOOLING	LAHUL & SPITI	175132
261	2030200402	GHS- GOUSHAL	LAHUL & SPITI	175132
262	2030202102	GHS- JOBRANG	LAHUL & SPITI	175139
263	2030203402	GHS- MOORING	LAHUL & SPITI	175139
264	2030301203	GHS CHIMRAT	LAHUL & SPITI	175142
265	2030302902	GHS SALGRAN	LAHUL & SPITI	175142
266	2030400302	GHS HULL	LAHUL & SPITI	172114
267	2030400502	GHS DEMUL	LAHUL & SPITI	172114
268	2030400602	GHS LALUNG	LAHUL & SPITI	172113
269	2030401202	GHS GULLING	LAHUL & SPITI	172117
270	2030401602	GHS DHANKHAR	LAHUL & SPITI	172113
271	2040100106	GHS NERI	KULLU	175129
272	2040100205	GHS FOZAL	KULLU	175129
273	2040100608	GHS HALLAN-1	KULLU	175130
274	2040100905	GHS PALCHAN	KULLU	175103
275	2040101803	GHS PRINI	KULLU	175143
276	2040102203	GHS BARAGRAN-BIHAL	KULLU	175129
277	2040102406	GHS NATHAN LARANKELO	KULLU	175104
278	2040102503	GHS JANA	KULLU	175104
279	2040200206	GHS DUGHILAG	KULLU	175102
280	2040200904	GHS SHIRAD	KULLU	175128
281	2040201304	GHS BAGAN	KULLU	175101
282	2040300207	GHS KHALOGI	KULLU	175126

283	2040300306	GHS CHESTHA	KULLU	175126
284	2040302003	GHS SACHANI	KULLU	175125
285	2040302605	GHS CHHENUR	KULLU	175125
286	2040302903	GHS SHAAT	KULLU	175105
287	2040303702	GHS MALANA	KULLU	175105
288	2040304605	GMS THELLA	KULLU	175141
289	2040400609	GHS HIRAB	KULLU	175192
290	2040401005	GHS PLACH	KULLU	175123
291	2040401106	GHS KALWARI	KULLU	175123
292	2040401904	GHS MANGLOR	KULLU	175123
293	2040402705	GHS SARI	KULLU	175134
294	2040402804	GHS KANON	KULLU	175134
295	2040403106	GHS ROWAR	KULLU	175134
296	2040403214	GHS RAILA	KULLU	175134
297	2040403405	GHS DEHURI	KULLU	175134
298	2040403604	GHS SHANGHAR	KULLU	175134
299	2040500205	GHS ROWA	KULLU	172033
300	2040500607	GHS SHUSH	KULLU	172025
301	2040501003	GHS NAMHONG	KULLU	172025
302	2040501406	GMS LADHAGI	KULLU	172032
303	2040502009	GHS SINVI	KULLU	172026
304	2040502306	GHS SHILLIJANJA	KULLU	172026
305	2040600105	GHS SARGA	KULLU	172201
306	2040600207	GHS KUSHWA	KULLU	172201
307	2040600404	GHS TUNAN	KULLU	172001
308	2040600505	GHS RANDAL	KULLU	172001
309	2040600606	GHS KASHOLI	KULLU	172001
310	2040600904	GHS DEEM	KULLU	172002
311	2040601006	GHS TWAR	KULLU	172002
312	2040601305	GHS SARAHAN	KULLU	172002
313	2040601704	GHS GHATTU	KULLU	172023
314	2040601804	GHS KOIL	KULLU	172023
315	2040602006	GHS DURAH	KULLU	172033
316	2040602103	GHS SHARVI	KULLU	172023
317	2050101401	GHS BARI GUMANU	MANDI	175001
318	2050101601	GHS NASLOH	MANDI	175001
319	2050102601	GHS BADOG	MANDI	175001
320	2050103302	GHS KOT MORSE	MANDI	175001
321	2050105801	GHS FARSH	MANDI	175121
322	2050107701	GHS TALYAHAR	MANDI	175001
323	2050108601	GHS KATHLAG	MANDI	175001
324	2050109201	GHS BAKHLI	MANDI	175124

325	2050205303	GHS KAMMAND	MANDI	175005
326	2050205403	GHS RIYAGARI	MANDI	175005
327	2050205802	GHS NISHU	MANDI	175005
328	2050206502	GHS BAGGI	MANDI	175005
329	2050207304	GHS BANDHI	MANDI	175124
330	2050208003	GHS HATAUN	MANDI	175124
331	2050208704	GHS TIHARI	MANDI	175005
332	2050211101	GHS TARYAMBLI	MANDI	175001
333	2050302102	GHS CHAMBI	MANDI	175018
334	2050303304	GHS KAPAHI	MANDI	175002
335	2050303703	GHS KALAHOD	MANDI	175002
336	2050304603	GHS ALSOO	MANDI	175036
337	2050307503	GHS BARI	MANDI	175018
338	2050309803	GHS BARTO	MANDI	175018
339	2050310006	GHS SEHLI	MANDI	174401
340	2050311903	GMS GHANGNOO	MANDI	175018
341	2050317801	GHS SAWAL	MANDI	175017
342	2050400102	GHS KAMAND	MANDI	175031
343	2050401002	GHS HARABOI	MANDI	175009
344	2050405802	GHS PAURA KOTHI	MANDI	175031
345	2050500602	GHS KHALANOO	MANDI	175003
346	2050502602	GHS BAGGI	MANDI	175052
347	2050505202	GHS CHOWKI CHANDRAHAN	MANDI	175023
348	2050506102	GHS BHARGOAN	MANDI	175003
349	2050508302	GHS SADIANA	MANDI	175001
350	2050602002	GHS BHANGROTU (G)	MANDI	175021
351	2050603302	GHS BAGGI	MANDI	175027
352	2050605002	GHS CHHAMYAR	MANDI	175027
353	2050611202	GHS KUMMI	MANDI	175027
354	2050611902	GHS LOHARA	MANDI	175027
355	2050616402	GHS MUNDROO	MANDI	175008
356	2050617601	GHS SIANJI	MANDI	175027
357	2050701102	GHS NANDI	MANDI	175124
358	2050703302	GHS TARAUR	MANDI	175029
359	2050703502	GHS CHACHIOT	MANDI	175028
360	2050704802	GHS KHARSI	MANDI	175029
361	2050706404	GSSS BARA	MANDI	175029
362	2050708601	GHS KANDHA	MANDI	175035
363	2050709401	GHS SHALLA	MANDI	175028
364	2050714202	GSSS MOVISERI	MANDI	175029
365	2050803102	GHS JAHAL	MANDI	175039
366	2050803702	GHS BROKHARI	MANDI	175031

367	2050817701	GHS BADHU	MANDI	175028
368	2050910701	GHS BHATKI DHAR	MANDI	175035
369	2051000501	GHS NARAYAN GARH	MANDI	175106
370	2051003802	GHS BANDAL	MANDI	175021
371	2051006803	G.H.S SUDHRANI	MANDI	175106
372	2051007903	G.H.S SERIBATWARA	MANDI	175121
373	2051017301	GSSS SLOT	MANDI	175124
374	2051103302	GHS KHUDDER	MANDI	175015
375	2051105002	GHS LAPAS	MANDI	175013
376	2051105202	GHS GALOO	MANDI	175015
377	2051106002	GSSS HARABAG	MANDI	175015
378	2051106603	GHS KUTGARH	MANDI	175013
379	2051108702	GHS MAJHARNOO	MANDI	175015
380	2051108801	GHS DRAHAL	MANDI	175015
381	2051115801	GHS DOHAG	MANDI	175015
382	2051116601	GHS ROPRI-KALEHRU	MANDI	175032
383	2051200802	GHS CHUCKOO	MANDI	175012
384	2051203902	GHS SAHAL	MANDI	176121
385	2051205002	GHS SILAG	MANDI	175012
386	2051209002	GHS SWAR	MANDI	175012
387	2051209702	GHS SARONJH	MANDI	175012
388	2051211202	GHS ARANG	MANDI	175005
389	2051214602	GHS KATHOG	MANDI	175012
390	2051217102	GHS SARNI	MANDI	175012
391	2051220501	GHS JHATINGRI	MANDI	175015
392	2051306702	GHS ALI PABO	MANDI	175014
393	2051311502	GHS SAGNEHAR	MANDI	175032
394	2051400102	GHS BAG PANDOL	MANDI	175032
395	2051401802	GHS KARSAL	MANDI	175016
396	2051402202	GHS PAPLOTU	MANDI	175032
397	2051404602	GHS SIMAS	MANDI	175016
398	2051405402	GHS KOLANG	MANDI	175016
399	2051405702	GHS KHADDAR	MANDI	175016
400	2051502502	GHS KASHAUHAL	MANDI	175011
401	2051504301	GHS GAWALPUR	MANDI	175011
402	2051505402	GHS CHOURI DHAR	MANDI	175011
403	2051506004	GHS POKHI	MANDI	175011
404	2051604302	GHS BELER DHAR	MANDI	175010
405	2051606502	GHS MAROTHI	MANDI	175046
406	2051607202	GHS ALSINDI	MANDI	171302
407	2051609002	GHS JARAL	MANDI	175038
408	2051615902	GHS SAHAJ	MANDI	175009

409	2051619602	GHS DHAR KANDLU	MANDI	175010
410	2051620201	GHS BAKHIROT	MANDI	175011
411	2051622902	GHS KHEEL	MANDI	175010
412	2051623201	GHS GHAIN	MANDI	175038
413	2051705903	GHS GEHRA	MANDI	175049
414	2051709502	GHS PINGLA	MANDI	175049
415	2051715601	GHS BAGRAGALU	MANDI	175024
416	2051802902	GHS SULPUR BAHU	MANDI	175004
417	2051804002	GSSS KHANOT	MANDI	175033
418	2051810902	GHS KALTHAR	MANDI	175033
419	2051904102	GHS NALYANA	MANDI	175026
420	2051904402	GHS RASAIN RALOO	MANDI	175042
421	2051906902	GHS KK GEHRA	MANDI	175026
422	2051909702	GHS HUKKAL	MANDI	175025
423	2052000103	G.H.S.BERI	MANDI	176090
424	2052003202	GHS BHARI	MANDI	175040
425	2052005002	GHS GIUN	MANDI	175040
426	2052010102	GHS REUR	MANDI	175040
427	2060100102	GHS BRAHLARI	HAMIRPUR (H.P.)	177026
428	2060101302	GHS KHIAH	HAMIRPUR (H.P.)	177020
429	2060101402	GHS NARELI	HAMIRPUR (H.P.)	177020
430	2060101702	GHS BHARTHIAN	HAMIRPUR (H.P.)	177029
431	2060103402	GHS DUGHA	HAMIRPUR (H.P.)	177001
432	2060105902	GHS JHATWAR	HAMIRPUR (H.P.)	177029
433	2060107002	GHS GULELA	HAMIRPUR (H.P.)	177001
434	2060107802	GHS BALOH	HAMIRPUR (H.P.)	177029
435	2060108002	GHS PATNAUN	HAMIRPUR (H.P.)	177023
436	2060108202	GHS BARI	HAMIRPUR (H.P.)	177001
437	2060108602	GHS NALANGAR	HAMIRPUR (H.P.)	174505
438	2060109102	GHS LOHAKHAR	HAMIRPUR (H.P.)	177023
439	2060109502	GHS SASAN	HAMIRPUR (H.P.)	171001
440	2060109602	GHS BAFFRIN	HAMIRPUR (H.P.)	177029
441	2060205401	GHS RANGAR	HAMIRPUR (H.P.)	176111
442	2060209102	GHS CHAMIANA	HAMIRPUR (H.P.)	176111
443	2060210401	GHS THANA DHAMRIANA	HAMIRPUR (H.P.)	176110
444	2060220604	GHS(GIRLS) SUJANPUR TIRA	HAMIRPUR (H.P.)	176110
445	2060221801	GHS BHALETH	HAMIRPUR (H.P.)	176108
446	2060222001	GHS KANERAR	HAMIRPUR (H.P.)	176110
447	2060302102	GHS BARARA	HAMIRPUR (H.P.)	177023
448	2060302803	GHS DHAMROL	HAMIRPUR (H.P.)	177024
449	2060302902	GHS BADEHAR	HAMIRPUR (H.P.)	176048
450	2060303202	GHS DHIRWIN	HAMIRPUR (H.P.)	176045

451	2060304402	GHS KUTHRIN	HAMIRPUR (H.P.)	176043
452	2060305002	GHS THATHWANI	HAMIRPUR (H.P.)	177501
453	2060306902	GHS KAKKAR	HAMIRPUR (H.P.)	177024
454	2060307002	GSSS BHUKKAR	HAMIRPUR (H.P.)	177024
455	2060307302	GHS LUDDER	HAMIRPUR (H.P.)	176045
456	2060308502	GHS SAMIRPUR	HAMIRPUR (H.P.)	177601
457	2060309403	GHS KANJIAN	HAMIRPUR (H.P.)	177025
458	2060310203	GHS AMROH	HAMIRPUR (H.P.)	177024
459	2060400502	GHS BASARAL	HAMIRPUR (H.P.)	177301
460	2060400902	GHS KOHLA	HAMIRPUR (H.P.)	177033
461	2060406502	GHS KOTLA KALLER	HAMIRPUR (H.P.)	177042
462	2060406902	GHS DANGRI	HAMIRPUR (H.P.)	177048
463	2060409802	GHS JIWANI	HAMIRPUR (H.P.)	177045
464	2060500603	GGHS BIJHARI	HAMIRPUR (H.P.)	176040
465	2060501803	GSSS BARSAR	HAMIRPUR (H.P.)	174305
466	2060502902	GHS LOHARLI	HAMIRPUR (H.P.)	176039
467	2060503402	GHS KARER	HAMIRPUR (H.P.)	174311
468	2060504302	GHS BALIAH	HAMIRPUR (H.P.)	174305
469	2060506202	GHS SAMTANA	HAMIRPUR (H.P.)	176042
470	2060508002	GHS KATHIANA	HAMIRPUR (H.P.)	176041
471	2060509002	GHS BUMBLOO	HAMIRPUR (H.P.)	177119
472	2060509802	GHS ROPRI	HAMIRPUR (H.P.)	176041
473	2060600601	GHS RANGAS	HAMIRPUR (H.P.)	177048
474	2060601702	GHS PANIYALI	HAMIRPUR (H.P.)	177040
475	2060602102	GHS JANSOOH	HAMIRPUR (H.P.)	177041
476	2060602202	GHS PANSAI	HAMIRPUR (H.P.)	177041
477	2060602502	GGHS DHANETA	HAMIRPUR (H.P.)	177041
478	2060602602	GHS HATHOL	HAMIRPUR (H.P.)	177041
479	2060603702	GHS PLAGH BRAHMNA	HAMIRPUR (H.P.)	177026
480	2060605502	GHS LANJIANA	HAMIRPUR (H.P.)	174405
481	2070101102	GHS CHHETTRAN	UNA	176601
482	2070102603	GHS KUTHAR BEET	UNA	174503
483	2070103002	GHS NANGAL KALAN	UNA	174301
484	2070103003	GHS BUTT KALAN	UNA	174301
485	2070103603	GHS POLIAN BEET	UNA	174503
486	2070200102	GHS JANKAUR	UNA	174303
487	2070200402	GHS BADEHAR	UNA	174306
488	2070201102	GHS BHAROLIAN KALAN	UNA	174306
489	2070202302	GHS FATTEWAL	UNA	174315
490	2070203304	GHS KOTLA KALAN	UNA	174303
491	2070203902	GHS LAMLEHRI	UNA	174303
492	2070204003	GHS BASAL (L)	UNA	174303

493	2070205202	GHS RAIPUR SAHORAN	UNA	174315
494	2070205302	GHS RAISARY	UNA	174303
495	2070207202	GHS AJOULI	UNA	174301
496	2070301004	GHS DEOLI	UNA	177212
497	2070301201	GHS DHAKKI	UNA	177208
498	2070301305	GHS GAGRET	UNA	177201
499	2070301602	GHS GUGLEHAR	UNA	177208
500	2070301903	GHS JADLA	UNA	177208
501	2070303102	GHS MAWA SINDHIAN	UNA	177206
502	2070304106	GHS SALOH BERI	UNA	174319
503	2070304205	GHS SANGHNAI	UNA	177212
504	2070400502	GHS CHAHBAG	UNA	177109
505	2070401502	GHS BHATER	UNA	177110
506	2070402202	GHS DHALWARI	UNA	177110
507	2070403402	GHS KADH	UNA	177213
508	2070403502	GHS KALRUHI	UNA	177203
509	2070404103	GHS KUNERAN	UNA	177219
510	2070500503	GHS ANDOURA	UNA	177203
511	2070502203	GHS CHAK SARAI	UNA	177210
512	2070502303	GHS CHALOLA	UNA	174303
513	2070505202	GHS MAIRI	UNA	177210
514	2070506402	GHS PANOH	UNA	174303
515	2070507803	GHS TEURI	UNA	174303
516	2070508102	GHS TAKARLA	UNA	177211
517	2070515901	GHS NANDPUR	UNA	177211
518	2070601902	GHS BHIAMBI	UNA	177038
519	2070602302	GHS BUDHAN	UNA	174308
520	2070602402	GHS BUDHWAR	UNA	174321
521	2070603002	GHS CHARARA	UNA	174307
522	2070603402	GHS CHURARI	UNA	177301
523	2070605902	GHS KIARIAN	UNA	174307
524	2070607302	GHS DHANET	UNA	174307
525	2070607402	GHS JATEHRI	UNA	174307
526	2070607902	GHS PAROIAN	UNA	174321
527	2070608502	GHS SANHAL	UNA	174321
528	2070608902	GSSS TALAI	UNA	174321
529	2070609302	GHS TANOH	UNA	174308
530	2080106702	GHS DAS GAON	BILASPUR (H.P.)	174001
531	2080108905	GHS BALAG KA GHAT	BILASPUR (H.P.)	174001
532	2080108906	GHS DHAR TATOH	BILASPUR (H.P.)	174001
533	2080109102	GHS BAUHAT KASOL	BILASPUR (H.P.)	174012
534	2080109702	GHS SAI BRAHMANA	BILASPUR (H.P.)	174001

535	2080114401	GHS PAROHI	BILASPUR (H.P.)	174001
536	2080115502	GHS LOHARDA	BILASPUR (H.P.)	174001
537	2080115802	GHS TEPRA	BILASPUR (H.P.)	174032
538	2080116903	GHS GHIAL	BILASPUR (H.P.)	174032
539	2080117702	GHS NIHARKHAN BASLA	BILASPUR (H.P.)	174001
540	2080200102	GHS NELLA	BILASPUR (H.P.)	174201
541	2080201506	GHS DABAT	BILASPUR (H.P.)	174002
542	2080202902	GHS LAKHNUN	BILASPUR (H.P.)	174015
543	2080206402	GHS MAKRI	BILASPUR (H.P.)	174201
544	2080207402	GHS KHARKARI	BILASPUR (H.P.)	174310
545	2080210102	GHS GARA	BILASPUR (H.P.)	174001
546	2080211302	GHS CHAMB BHAIWAN	BILASPUR (H.P.)	174310
547	2080212002	GHS SWARGHAT	BILASPUR (H.P.)	174011
548	2080219202	GHS JAMLI	BILASPUR (H.P.)	174001
549	2080220302	GHS MAITHI	BILASPUR (H.P.)	174001
550	2080308502	GHS DHANI PAKHAR	BILASPUR (H.P.)	174017
551	2080310603	GHS JABLOO	BILASPUR (H.P.)	174034
552	2080311502	GHS BALGHAR	BILASPUR (H.P.)	174031
553	2080312203	GHS BALA	BILASPUR (H.P.)	174034
554	2080312303	GHS BAROHA	BILASPUR (H.P.)	174031
555	2080314202	GHS BADGAON	BILASPUR (H.P.)	174029
556	2080314702	GHS BALOH	BILASPUR (H.P.)	174029
557	2080316004	GHS NAGHAIR	BILASPUR (H.P.)	174030
558	2080319502	GHS GANGLOH	BILASPUR (H.P.)	174030
559	2080320602	GHS MALANGAN	BILASPUR (H.P.)	174029
560	2080402403	GHS TARAUN	BILASPUR (H.P.)	174027
561	2080403402	GHS PANTEHRA	BILASPUR (H.P.)	174028
562	2080403702	GHS SALAON	BILASPUR (H.P.)	174028
563	2080405202	GHS LADDA CHAUGAN	BILASPUR (H.P.)	174026
564	2080406102	GHS TALWARA	BILASPUR (H.P.)	174026
565	2080414702	GHS SOHAL	BILASPUR (H.P.)	174021
566	2080416502	GHS BARI MAJHERWAN	BILASPUR (H.P.)	174021
567	2080417004	GHS CHHAT	BILASPUR (H.P.)	174029
568	2080417501	GHS KALLAR	BILASPUR (H.P.)	174029
569	2080419302	GHS CHHANDOH	BILASPUR (H.P.)	174023
570	2080510902	GHS KOTHI	BILASPUR (H.P.)	174021
571	2080511203	GHS BAIHNA JATAN	BILASPUR (H.P.)	174001
572	2080512503	GHS BHAGER	BILASPUR (H.P.)	174021
573	2080513902	GHS PANOH	BILASPUR (H.P.)	174004
574	2090100801	GHS BHOJ ANJI	SOLAN	173211
575	2090100901	GHS BOHLI	SOLAN	173229
576	2090101001	GHS DAGSHAI	SOLAN	173229

577	2090101401	GHS KAKKARHATTI	SOLAN	173206
578	2090101801	GHS SHARDAGHAT	SOLAN	173207
579	2090101901	GHS SUBATHU (G)	SOLAN	173206
580	2090102401	GHS CHEWA	SOLAN	173229
581	2090102701	GHS JADLI	SOLAN	173207
582	2090103101	GHS HARIPUR	SOLAN	173206
583	2090103601	GHS KOTHON	SOLAN	173212
584	2090103701	GHS SANAWAR	SOLAN	173202
585	2090200701	GHS DHAYLA	SOLAN	173206
586	2090201201	GHS DURGAPUR DHARDI	SOLAN	173206
587	2090202301	GHS DHAKRIANA	SOLAN	173206
588	2090202501	GHS MANDHALA	SOLAN	174103
589	2090209002	GHS DARWA	SOLAN	173206
590	2090300201	GHS SHAMROR	SOLAN	173223
591	2090308901	GHS DOL KA JUBBAR	SOLAN	173217
592	2090309501	GHS MANJHOL	SOLAN	173215
593	2090310001	GHS GHAINTEE	SOLAN	173217
594	2090314101	GHS KOTLA	SOLAN	173212
595	2090400702	GHS NANGAL	SOLAN	174101
596	2090401101	GHS GUNAHA	SOLAN	174102
597	2090401401	GHS SAI CHAROG	SOLAN	174102
598	2090401501	GHS KUNDLU	SOLAN	174101
599	2090402201	GHS MALANI	SOLAN	174101
600	2090402701	GHS NAWAN GRAM	SOLAN	174101
601	2090414601	GHS DHANG	SOLAN	174101
602	2090415301	GHS RAJ PURA	SOLAN	174101
603	2090501802	GHS RAURI	SOLAN	171102
604	2090503501	GHS HANUMAN-BADOG	SOLAN	173235
605	2090503701	GSSS GHANAGU GHAT	SOLAN	171102
606	2090505701	GHS GHARIACH	SOLAN	173221
607	2090506201	GHS BASANTPUR	SOLAN	173221
608	2090506501	GHS MANGROOR	SOLAN	171102
609	2090506801	GHS PANJAL	SOLAN	173221
610	2090507001	GHS BERAL	SOLAN	171102
611	2090507101	GHS KANSWALA	SOLAN	171102
612	2090507201	GHS BHARARIGHAT	SOLAN	173235
613	2090602302	GHS MANGOO	SOLAN	171102
614	2090603302	GHS SHEHROL	SOLAN	173221
615	2090604302	GHS BAWASI	SOLAN	173218
616	2090604402	GHS BATAL	SOLAN	173208
617	2090604502	GHS MANJYAT	SOLAN	173208
618	2090604902	GHS BAKHALAG	SOLAN	173208

619	2090605803	GHS KASHLOG	SOLAN	171102
620	2090605902	GHS PAKOTI	SOLAN	171102
621	2090607002	GHS KOTLI	SOLAN	173208
622	2090607202	GHS (G) UCHAGAON KUNIHAR	SOLAN	173207
623	2090608201	GSSS DANOGHAT	SOLAN	171102
624	2090700701	GHS LAGDAGHAT	SOLAN	174102
625	2090700801	GHS BADHOKHARI	SOLAN	173218
626	2090701701	GHS CHANAL MAJRA	SOLAN	174101
627	2090701901	GHS BARRIAN	SOLAN	174101
628	2090702501	GHS JUBAKHAR	SOLAN	174102
629	2090702701	GHS LODI MAJRA	SOLAN	174101
630	2090702801	GHS MANLOG KALAN	SOLAN	173218
631	2090703301	GHS BAILA	SOLAN	174102
632	2100100402	GHS KOTA PAB	SIRMAUR	173029
633	2100102203	GHS MANDWATCH	SIRMAUR	173023
634	2100102804	GHS BHALONA	SIRMAUR	173023
635	2100103305	GHS JAMU KOTI	SIRMAUR	173022
636	2100103602	GHS BHATGARH	SIRMAUR	173022
637	2100201004	GHS JARAG	SIRMAUR	173022
638	2100201902	GHS GHATON	SIRMAUR	173023
639	2100203703	GHS PANAR	SIRMAUR	173022
640	2100203802	GHS DADAHU (GIRLS)	SIRMAUR	173022
641	2100205602	GHS KAMLAR	SIRMAUR	173023
642	2100300202	GHS JABBAL KA BAGH	SIRMAUR	173001
643	2100303102	GHS MATTAR	SIRMAUR	173001
644	2100303604	GMS DHAUN	SIRMAUR	173001
645	2100303702	GHS RAMA	SIRMAUR	173001
646	2100400503	GHS DEVNA THANGA	SIRMAUR	173104
647	2100401003	GHS DEVA MANAL	SIRMAUR	173104
648	2100401108	GHS CHOKAR	SIRMAUR	173104
649	2100401303	GHS PUNNER DHAR	SIRMAUR	173104
650	2100402203	GHS BHAJOND	SIRMAUR	173023
651	2100403602	GHS CHARNA	SIRMAUR	173104
652	2100404204	GHS GEHAL DEMAINA	SIRMAUR	173023
653	2100404403	GHS DEURI KHARHAN	SIRMAUR	173023
654	2100405205	GHS MANAL DHOCHI	SIRMAUR	173023
655	2100500803	GHS MANPUR DEWRA	SIRMAUR	173025
656	2100501402	GHS MUGLAWALA KARTARPUR	SIRMAUR	173028
657	2100501803	GHS KHODRI MAJRI	SIRMAUR	173025
658	2100502302	GHS BATTAMANDI	SIRMAUR	173025
659	2100502306	GMS KISHANPURA	SIRMAUR	173025

660	2100502403	GHS BEHRAL	SIRMAUR	173025
661	2100504003	GHS RAMPURGHAT	SIRMAUR	173025
662	2100504702	GHS CHHACHHETI	SIRMAUR	173029
663	2100602002	GHS CHHOGTALI	SIRMAUR	173101
664	2100602602	GHS BHUIRA	SIRMAUR	173101
665	2100603002	GHS GADHOL PIRAG	SIRMAUR	173101
666	2100603603	GHS DHAROTI	SIRMAUR	173101
667	2100604502	GHS MANDIA GHAT	SIRMAUR	173101
668	2100605303	GHS DAHAN	SIRMAUR	173101
669	2100605702	GHS PABIYANA	SIRMAUR	173101
670	2100607702	GHS KOTLA BANGI	SIRMAUR	173223
671	2100703202	GHS MEHANDO BAGH	SIRMAUR	173024
672	2100705102	GHS NAYA GAON	SIRMAUR	173024
673	2100706302	GHS MADIGHAT	SIRMAUR	173024
674	2100708202	GHS DHARYAR KANGER	SIRMAUR	173024
675	2100708402	GHS PANWA	SIRMAUR	173229
676	2100708602	GHS SARAHAN (GIRLS)	SIRMAUR	233024
677	2100708902	GHS SIRMAURI MANDIR	SIRMAUR	173024
678	2100712102	GHS APPRON	SIRMAUR	173024
679	2100712402	GHS BANAH KI SER	SIRMAUR	173024
680	2100801001	GHS SADIYAR	SIRMAUR	173029
681	2100802004	GHS SAKHOLI	SIRMAUR	173029
682	2100806004	GHS DANDA PAGAR	SIRMAUR	173025
683	2100901406	GHS DAYA	SIRMAUR	173027
684	2100902004	GHS JHAKANDO	SIRMAUR	173027
685	2100902404	GHS KHADKAHAN	SIRMAUR	173027
686	2100902506	GHS RONHAT	SIRMAUR	173027
687	2100903102	GHS JASWI	SIRMAUR	173027
688	2101005103	GSSS BIKRAM BAGH	SIRMAUR	173001
689	2101100603	GHS CHOWKI MIRGWAL	SIRMAUR	173029
690	2101100703	GHS BARWAS	SIRMAUR	173029
691	2101100904	GHS SHAWGA KANDO	SIRMAUR	173029
692	2101101103	GHS PAMTA	SIRMAUR	173029
693	2101101505	GHS SHARLI MANPUR	SIRMAUR	173029
694	2101200902	GHS DHAR TIKKERI	SIRMAUR	173024
695	2101201002	GSSS DINGER KINNER	SIRMAUR	173001
696	2101201402	GHS BONGALI KHENCH	SIRMAUR	173101
697	2101201502	GHS SODA DHIYARI	SIRMAUR	173101
698	2101201902	GHS DARON DEVRIYA	SIRMAUR	173024
699	2101202202	GHS MALHOTI	SIRMAUR	173024
700	2101202502	GHS SARSOO	SIRMAUR	173024
701	2101205002	GHS KOTLA BAROG	SIRMAUR	173024

702	2101300202	GHS BARTHAL MADHANA	SIRMAUR	173022
703	2101300902	GHS SAINWALA	SIRMAUR	173021
704	2101301203	GHS MISSERWALA	SIRMAUR	173021
705	2101301403	GHS PALHORI	SIRMAUR	135103
706	2101301802	GSSS HARIPURKHOL	SIRMAUR	173001
707	2110101102	GHS LAKADHAR	SHIMLA	171208
708	2110102202	GHS KHAROT	SHIMLA	171208
709	2110102702	GHS KHASHDHAR	SHIMLA	171208
710	2110103102	GHS GUMMA	SHIMLA	171208
711	2110103802	GHS JARKOT	SHIMLA	171208
712	2110105002	GHS JAGLIKH	SHIMLA	171208
713	2110105102	GHS TANGNOO	SHIMLA	171208
714	2110105402	GHS BOSARI	SHIMLA	171208
715	2110105902	GHS KHABAL	SHIMLA	171208
716	2110106702	GHS CHILALA	SHIMLA	171208
717	2110106902	GHS DUGYANI	SHIMLA	171208
718	2110108702	GHS ROHAL	SHIMLA	171208
719	2110109302	GHS RANOL	SHIMLA	171214
720	2110110202	GHS TODSA	SHIMLA	171214
721	2110201102	GSSS DHABAS	SHIMLA	171211
722	2110202102	GHS JHOKAR	SHIMLA	171217
723	2110204302	GHS JHINA	SHIMLA	171211
724	2110208601	GHS KHAGNA	SHIMLA	171211
725	2110208701	GHS JHIKNIPUL	SHIMLA	171211
726	2110300502	GHS BAJROLIPUL	SHIMLA	171220
727	2110302802	GHS CHANAIR	SHIMLA	171220
728	2110303802	GHS KUTHAR	SHIMLA	171226
729	2110305402	GHS DEOTHI	SHIMLA	171220
730	2110400102	GHS JISKOON	SHIMLA	171221
731	2110501002	GHS JHAGTAN	SHIMLA	171216
732	2110502702	GHS KUDDU	SHIMLA	171206
733	2110507206	GHS JUBBAL(GIRLS)	SHIMLA	171205
734	2110508501	GHS SARI	SHIMLA	171206
735	2110601602	GHS JABRI	SHIMLA	171103
736	2110603402	GHS NEHRA	SHIMLA	171011
737	2110603702	GHS KHALINI	SHIMLA	171009
738	2110605902	GHS KOT GEHA	SHIMLA	173215
739	2110702102	GHS ALAWONG	SHIMLA	171204
740	2110702602	GHS GLEHA	SHIMLA	171204
741	2110702702	GHS BAGHAL	SHIMLA	171225
742	2110703002	GHS BAKHOL	SHIMLA	171202
743	2110705602	GHS DAKHAL	SHIMLA	171204

744	2110707202	GHS NAGAN	SHIMLA	171202
745	2110805202	GHS KACHARI	SHIMLA	171213
746	2110805902	GHS GALANI	SHIMLA	172024
747	2110806702	GHS BHARERI	SHIMLA	172024
748	2110809602	GHS KOTIGHAT	SHIMLA	171212
749	2110810301	GHS THANEDHAR (BARUBAG)	SHIMLA	172030
750	2110902702	GHS CHIKHAR	SHIMLA	171012
751	2110903602	GHS BHARARIA	SHIMLA	171012
752	2110906702	GHS MOOLKOTI	SHIMLA	171007
753	2110906802	GHS BAGTHAL	SHIMLA	171007
754	2111000402	GSSS SANDHU	SHIMLA	171222
755	2111000502	GHS KATHOG	SHIMLA	171222
756	2111001802	GHS KOT SHILARU	SHIMLA	171213
757	2111004302	GHS KELVI	SHIMLA	171212
758	2111100502	GHS JAHU	SHIMLA	171213
759	2111100902	GHS GAHAN	SHIMLA	171213
760	2111101202	GHS KHARAHAN	SHIMLA	171213
761	2111202402	GHS BHARNOO	SHIMLA	171210
762	2111202603	GHS KUTHAR	SHIMLA	171210
763	2111206002	GHS TELOR	SHIMLA	171210
764	2111207102	GHS KANDEL	SHIMLA	171210
765	2111207202	GHS HIRAH	SHIMLA	171210
766	2111210002	GHS BIJMAL	SHIMLA	171210
767	2111210702	GHS DEIYA	SHIMLA	171210
768	2111213502	GHS SHAMTHA	SHIMLA	171210
769	2111214002	GHS GUMMA	SHIMLA	171210
770	2111300702	GHS BADHAWALI	SHIMLA	172022
771	2111303002	GHS NIRTH	SHIMLA	172001
772	2111305502	GHS LALSA	SHIMLA	172001
773	2111307102	GHS DEVNAGAR	SHIMLA	172022
774	2111309002	GHS RACHOLI	SHIMLA	172001
775	2111310002	GHS MUNISH	SHIMLA	172022
776	2111310702	GHS JARASHI	SHIMLA	172022
777	2111312602	GHS PALZARA	SHIMLA	172022
778	2111316002	GHS DARKALI	SHIMLA	172022
779	2111401902	GHS BHAMNOLI	SHIMLA	171224
780	2111403702	GHS SUNDER NAGAR	SHIMLA	171225
781	2111406802	GHS SHAKHAL	SHIMLA	171206
782	2111409603	GHS SEEMA	SHIMLA	171207
783	2111500602	GHS BHARARI	SHIMLA	171001
784	2111501102	GHS CHORA MAIDAN	SHIMLA	171004
785	2111503103	GHS JAKHU	SHIMLA	171001

786	2111503402	GHS KAITHU	SHIMLA	171003
787	2111503502	GHS ANNADALE	SHIMLA	171003
788	2111504502	GHS CHANOG	SHIMLA	171011
789	2111505002	GHS KAINA	SHIMLA	171011
790	2111505602	GHS KRISHNA NAGAR	SHIMLA	171001
791	2111507802	GHS SHAMLAGHAT	SHIMLA	171011
792	2111509702	GHS TUTIKANDI	SHIMLA	171004
793	2111603402	GHS PATTUKHAR	SHIMLA	171301
794	2111604002	GHS PANDOA	SHIMLA	171019
795	2111605302	GHS NEEN	SHIMLA	171007
796	2111605602	GHS GARKHAN	SHIMLA	171018
797	2111606502	GHS NEHRA	SHIMLA	171103
798	2111606802	GHS CHANWAG	SHIMLA	171103
799	2111607702	GHS BHARARA	SHIMLA	171018
800	2111609502	GHS DOMEHAR	SHIMLA	171018
801	2111704202	GHS TYALI	SHIMLA	171209
802	2111705202	GHS JAIS	SHIMLA	171201
803	2111707801	GHS DHAMANDRI	SHIMLA	171209
804	2111800902	GHS TIKKER	SHIMLA	171217
805	2111801002	GHS KANDA-BANAH	SHIMLA	171217
806	2111803902	GHS NAURA	SHIMLA	171217
807	2111900202	GHS SARPARA	SHIMLA	172201
808	2111900501	GHS PHANCHA 15/20	SHIMLA	172101
809	2111900602	GHS JHAGORI 15/20	SHIMLA	172101
810	2111901402	GHS KIYAO 15/20	SHIMLA	172101
811	2111902601	GHS KAIBIL 15/20	SHIMLA	172101
812	2111903101	GHS BADHAL	SHIMLA	172101
813	2112001502	GHS SHARONTHA	SHIMLA	171203
814	2112002502	GHS KADIWAN	SHIMLA	171203
815	2120100701	G.H.S. YANGPA	KINNAUR	172118
816	2120100901	GHS NATHPA	KINNAUR	172115
817	2120101101	G.H.S. CHAURA	KINNAUR	172101
818	2120101201	G.H.S. SUNGRA	KINNAUR	172115
819	2120101501	G.H.S. KANGOS	KINNAUR	172115
820	2120101801	G.H.S. BARI	KINNAUR	172115
821	2120102101	G.H.S. PANVI	KINNAUR	172104
822	2120106802	G.H.S RAMNI	KINNAUR	172104
823	2120200301	G.H.S. BARANG	KINNAUR	172107
824	2120200701	G.H.S. CHHITKUL	KINNAUR	172106
825	2120200801	G.H.S. BATSERI	KINNAUR	172106
826	2120200901	G.H.S. BRUA	KINNAUR	172105
827	2120201301	GHS CHANSU	KINNAUR	172106

828	2120201601	G.H.S. SHONG	KINNAUR	172105
829	2120300201	G.H.S. NESANG	KINNAUR	172110
830	2120300701	G.H.S. HANGO	KINNAUR	172112
831	2120300901	GHS ASRANG	KINNAUR	172109
832	2120301901	G.H.S. NAKO	KINNAUR	172111
833	2120302101	G.H.S. THANGI	KINNAUR	172109
834	2120302601	G.H.S. NAMGIA	KINNAUR	172111
835	2120308902	G.H.S SHALKHER	KINNAUR	172111

List of 70 Govt. Sr. Sec. Schools/Govt. High Schools

Sr.	UDISE CODE	Name of the School	District	PIN CODE
1	2020708102	GHS(G) REHAN	KANGRA	176022
2	2020807802	GSSS SUGH BHATOLI	KANGRA	176022
3	2020902201	GHS HARNOTA	KANGRA	176021
4	2021808102	GSSS GARAN	KANGRA	176201
5	2040201407	GMS CHANSARI	KULLU	175101
6	2040202205	GMS JINDORE	KULLU	175128
7	2040301905	GSSS THARAS	KULLU	175125
8	2040302503	GSSS SHIAH	KULLU	175141
9	2040400305	GSSS PUJALI	KULLU	175123
10	2040401604	GSSS BATHAD	KULLU	175123
11	2040402505	GSSS KOTLA	KULLU	175106
12	2040402906	GSSS BARAHEIN	KULLU	175134
13	2040501306	GMS KUTWA	KULLU	172032
14	2040502307	GHS SHOWAD	KULLU	172026
15	2040502504	GSSS DIGERH	KULLU	172026
16	2050203603	GSSS GHARAN	MANDI	175124
17	2050301002	GSSS MALOH	MANDI	175018
18	2050319301	GSSS BATWARA	MANDI	175017
19	2050402001	GSSS DOGHARI	MANDI	171302
20	2050405002	GSSS GHIRI	MANDI	175031
21	2050602902	GSSS GHASNOO	MANDI	175006
22	2050604202	GSSS BAGLA	MANDI	175021
23	2050609602	GSSS MERA MASIT	MANDI	195036
24	2050706204	GSSS PARWARA	MANDI	175029
25	2050715502	GSSS DEVDHAR	MANDI	175029
26	2050908002	GSSS BIHNI	MANDI	175047
27	2051000901	GSSS SARACHI	MANDI	175124
28	2051001101	GSSS GHAT	MANDI	175123
29	2051001403	GSSS DEVDHAR	MANDI	175106

30	2051002001	GSSS KHANI	MANDI	175106
31	2051005904	GSSS GHANIAR	MANDI	175106
32	2051500202	GSSS KUNHU	MANDI	171304
33	2051506601	GSSS MAHOG	MANDI	175011
34	2051507303	GSSS MAINDHI	MANDI	175011
35	2051509202	GSSS NANJ	MANDI	175011
36	2051801302	GSSS KOLNI DHALWAN	MANDI	175024
37	2052004002	GSSS JHANGI	MANDI	176090
38	2060301702	GSSS MANOH	HAMIRPUR (H.P.)	176044
39	2060500202	GSSS DHABIRI	HAMIRPUR (H.P.)	176049
40	2070101502	GSSS GONDPUR BULLA	UNA	176601
41	2070201903	GHS DANGOLI	UNA	174303
42	2070303403	GSSS OEL	UNA	177206
43	2070402004	GHS DANGOH	UNA	177204
44	2070502402	GHS CHURURU	UNA	177211
45	2080302603	GSSS BHAROLI KALAN	BILASPUR (H.P.)	174035
46	2080313102	GSSS GHARAHAN	BILASPUR (H.P.)	174030
47	2080415102	GSSS KATHALAG	BILASPUR (H.P.)	174029
48	2080512605	GSSS AMER PUR	BILASPUR (H.P.)	174021
49	2090201001	GSSS GHARER	SOLAN	173233
50	2090506001	GSSS BUGHAR	SOLAN	171102
51	2090700201	GSSS GULLARWALA	SOLAN	173205
52	2090703203	GSSS CHAMDAR	SOLAN	174102
53	2100202502	GHS MAINA	SIRMAUR	173023
54	2101003902	GSSS SAINWALA	SIRMAUR	173030
55	2110104502	GSSS PEKHA	SHIMLA	171208
56	2110109102	GSSS SARIBASA	SHIMLA	171214
57	2110400902	GSSS DODRA	SHIMLA	171221
58	2110603302	GSSS RAJHANA	SHIMLA	171009
59	2111104602	GSSS BARACH(NAINGARH)	SHIMLA	172001
60	2111108002	GSSS SHOLI	SHIMLA	172001
61	2111303402	GSSS KASHAPAT(KANDI)	SHIMLA	172022
62	2111402302	GSSS BHALOO	SHIMLA	171224
63	2111411002	GSSS SAMOLI	SHIMLA	171204
64	2111610301	GHS MONDOR GHAT	SHIMLA	171301
65	2111702102	GSSS DHARECH	SHIMLA	171209
66	2111705702	GHS MAJHAR	SHIMLA	171209
67	2111707102	GHS KIARTOO	SHIMLA	171201
68	2111707701	GHS JUGGER	SHIMLA	171209
69	2111801302	GSSS KAFLAH	SHIMLA	171217
70	2111804402	GSSS BHALOO	SHIMLA	171217

List of 5 Smart Schools (Govt. Sr. Secondary Schools)

Sr. No	Constitutency	Name of School	District
1	Kasumpati	Lalpani	Shimla
2	Karsog	Karsog	Mandi
3	Nurpur	Rehan	Kangra
4	Hamirpur	Hamirpur (Boys)	Hamirpur
5	Ghumarwin	Gumarwin (Girls)	Bilaspur